

**Technical White Paper:
Practical Guidelines for Incorporating
Adult Pacific Lamprey Passage at Fishways
June 20, 2017**

Recommended citation format: Pacific Lamprey Technical Workgroup. 2017. Practical guidelines for incorporating adult Pacific lamprey passage at fishways. June 2017. White Paper. 47 pp + Appendix. Available online: <https://www.fws.gov/pacificlamprey/mainpage.cfm>

Contents

1	ABSTRACT	1
2	INTRODUCTION	1
3	SUMMARY OF RELEVANT BIOLOGICAL INFORMATION	3
3.1	Life History	3
3.2	Swimming Speeds	3
3.3	Burst and Attach Locomotion	4
3.4	Climbing Behavior	4
3.5	Lamprey Behavior in Fishways	4
4	TYPES OF SALMON FISHWAYS	9
5	LAMPREY PASSAGE IN SALMON FISHWAYS	10
5.1	Attraction Flows and Entrance Conditions	11
5.1.1	Operational Changes at Entrances	12
5.1.2	Physical Modifications to Entrances.....	13
5.2	Corners/ Sharp Angles	13
5.3	Bulkhead Slots/Stop Log Guides	14
5.4	Diffuser Grating for Attraction Water Supply	14
5.5	Resting Areas/Refuge Boxes.....	15
5.6	Attachment Surfaces	16
5.7	Collection Channels	16
5.8	Junction Pools and Transition Pools	17
5.9	Temperatures in Fishways.....	18
5.10	Predation associated with Fishways	18
5.11	Weir Sections.....	19
5.11.1	Overflow Weirs/ Submerged Orifices at Salmon Fishways	19
5.11.2	Serpentine Weirs.....	19
5.11.3	Differential Between Pools.....	20

5.11.4	Bollards	20
5.12	Counting Stations and Associated Features.....	21
5.12.1	Counting Windows	21
5.12.2	Lighting.....	22
5.12.3	Picket Leads	22
5.13	Cul de Sacs and Dead Ends	23
5.14	Salmon Fishway Exits	23
6	LITERATURE CITED	43

LIST OF TABLES:

- Table 1. Lamprey swimming abilities and behaviors relative to water velocities.
- Table 2. Typical velocities encountered in upstream fish fishways designed for salmonids.
- Table 3. Summary table of guidelines, recommendations, and key uncertainties for passage of adult Pacific Lamprey in fishways, with associated literature or case studies.

LIST OF FIGURES:

- Figure 1. Lamprey issues with overflow weirs and suggested improvements.
- Figure 2. Lamprey issues with submerged orifices and suggested improvements for passage.
- Figure 3A. Lamprey impediments and remedies at vertical slot fishways.
- Figure 3B. Ramp for situations where there is a sill or a sill block.
- Figure 4. Lamprey issues at serpentine weirs.
- Figure 5. Lamprey issues with various fishway features.
- Figure 6. Improved stop log slots (cast-in-place slot version).
- Figure 7A. Lamprey issues with diffusers.
- Figure 7B. Lamprey improvements at diffusers (auxiliary water gratings).
- Figure 8. Lamprey refuge box, and typical placement of refuge box in fishway.

APPENDIX A: Case Studies of Fishway Modifications to Improve Pacific Lamprey Passage.

1 ABSTRACT

Anadromous fishes must migrate between the ocean and upriver spawning grounds to complete their life cycles. Many years and much effort has been expended to provide safe passage at human-made barriers for anadromous salmon and steelhead (*Oncorhynchus* spp.) in Pacific Northwest rivers, but there is another culturally and ecologically significant anadromous fish that has been overlooked until recently: the Pacific Lamprey (*Entosphenus tridentatus*). The objectives of this paper include:

- Summarize pertinent information on adult Pacific Lamprey passage capabilities from existing literature; and
- Provide a practical technical reference on how to accommodate migrations of adult Pacific Lamprey (new construction and retrofits of existing structures) for persons designing, operating, managing and maintaining fish barriers and fishways.

This paper will discuss modifications that can be made to typical adult salmonid fishway designs to accommodate and improve upstream passage for adult Pacific Lamprey without compromising conditions for salmonids, recognizing that in some cases existing salmonid fishways cannot be readily modified to provide fully unimpaired passage for lamprey. This paper will also include discussion on using lamprey-specific structures to improve passage of adult Pacific Lamprey. This paper relies on existing research, much of which has focused on the impediments to upstream migrating adult Pacific Lamprey, and the best professional judgment where data are insufficient. The primary goal of this paper is to provide recommendations for improving passage to upstream migrating adult Pacific Lamprey in fishways designed for salmon species, hereafter referred to as “*salmon fishways*.” Several case studies are also provided to demonstrate successful passage improvements for lamprey throughout the Pacific Northwest.

2 INTRODUCTION

Pacific Lamprey *Entosphenus tridentatus* are an anadromous species of cultural significance to Native American Tribes (Close et al. 2002) and of ecological importance to freshwater ecosystems of the Pacific Rim, from California to Alaska and Japan (Scott and Crossman 1973). Available evidence indicates that the abundance of Pacific Lamprey is in steep decline (Moser and Close 2003, Moser and Mesa 2009, Luzier et al. 2011). In recent years, more efforts have been expended to better understand the biology, ecology, distribution, and relative abundance of Pacific Lamprey, and to address factors that negatively affect their populations. Since early 2000, research in the Columbia River Basin has highlighted the need to understand migration requirements of Pacific Lamprey, and improve adult upstream passage to spawning grounds from the ocean. Outmigrating larval and juvenile Pacific Lamprey also experience significant mortalities at various dams and water diversion operations. Downstream passage and screening requirements for larval and juvenile Pacific Lamprey are therefore also important, but are outside the scope of this paper. The goal of this paper is providing guidance to improve upstream passage of adult Pacific Lamprey in fishways originally designed for salmon.

Pacific Lamprey are anguilliform swimmers,¹ and this locomotion mode is poorly suited for passing some of the high-velocity, highly turbulent features common to fishways constructed for salmon (e.g., Moser et al. 2002a). Species selectivity in fishways is a design and management conundrum worldwide

¹ A type of swimming practiced by highly flexible fish such as eels, in which most of the body length undulates such that over a half a sinusoidal wave is formed (<http://www.encyclopedia.com/science/dictionaries-thesauruses-pictures-and-press-releases/anguilliform-swimming>).

(e.g., see Agostinho et al. 2002, 2007; Mallen-Cooper and Brand 2007; Naughton et al. 2007; Moser et al. 2011; Johnson et al. 2012). Historically — as in the case of salmon on the West Coast of the United States — fishways were designed and optimized for economically important fish species, namely strong swimming species such as salmon (*Oncorhynchus* spp.) and steelhead *O. mykiss* (Clay 1995, Castro-Santos et al. 2013; Keefer et al. 2010; Kirk et al. 2016). Consideration for other fish species was not an overriding design factor when most of these fishways were originally designed and built (Katopodis and Williams 2012; Keefer et al. 2010; Kirk et al. 2016). It has been observed that many salmon fishways are difficult for lamprey to ascend for various reasons, such as velocity, turbulence, overall energy required, and exposure to predation.

Due to the difference in swimming behaviors between Pacific Lamprey and salmonids, certain attributes (i.e., velocity, lack of attachment surfaces) of salmon fishways create barriers or impediments to upstream lamprey migration (Keefer et al. 2010). Recent evaluations of lamprey passage at lower Columbia River dams have shown that only ~ 50-89% of upstream migrating adult Pacific Lamprey successfully pass fishways at individual dams (USACE 2012; Keefer et al. 2013a, 2013b).

Approximately 50% of lamprey that entered fishways at Bonneville Dam eventually passed (Keefer et al. 2013a). The median values for the same metric were ~68% at The Dalles Dam fishways (USACE 2012), ~51% at John Day Dam (USACE 2012), and 73% to 89% at McNary Dam (Keefer et al. 2013b).

The effect of this potential prohibition of passage of adult Pacific Lamprey in salmonid fishways was well summarized by Keefer et al. (2010): “*the mismatch between operational criteria in the Columbia River dam fishways and Pacific Lamprey swim performance almost certainly contributes to low dam passage efficiency and often protracted lamprey passage times.*” Design criteria for salmon fishways create structural and velocity challenges that require repeated attempts by adult Pacific Lamprey and longer passage times by them, which may in turn lead to higher energetic costs and physiological exhaustion (Keefer et al. 2010). Adult Pacific Lamprey do not feed during their upstream migration and must rely on stored energy reserves. Energy expended by successful adult lamprey migrants in negotiating a salmon fishway could result in physiological compromises that negatively affect their reproductive potential, and ultimately population productivity upstream of these fishways (Keefer et al. 2010).

Given that recovery time from exhaustive exercise for adult Pacific Lamprey in the laboratory is 1 to 4 hours (Mesa et al. 2003), passage failure may occur due to the cumulative effects on lamprey endurance, motivation, or both when considering either local (e.g., weir to weir) or large scale (dam to dam) movements, and not necessarily the inability of overcoming a single passage challenge (Kirk et al. 2016). Energetic reserves or motivation may be exceeded when lamprey encounter multiple challenges when attempting to pass several dams into the interior Columbia Basin (Kirk et al. 2016). Keefer et al. (2009) found that fewer than 5% passed the lowest four dams to reach the interior Columbia River basin, although some proportion of the remaining 95% entered tributaries to the lower Columbia and presumably spawned there. Some fishways may be a complete barrier for a portion of the migrating population, as research suggests that some obstacles are impassable for relatively small adult Pacific Lamprey, which may have reduced swimming abilities or endurance relative to larger individuals (Keefer et al. 2009; Kirk et al. 2016).

There are several other factors that affect lamprey passage in addition to high velocity and high turbulence features of fishways, but they are not yet well understood. These factors include the presence

of predators, hydraulic cues, temperature and motivation. For example, much of the apparent fishway rejection at Bonneville Dam occurs in the low velocity/low turbulence environments of collection channels and transition pools (Keefer et al. 2012). In these areas, lamprey are free-swimming and are not constrained by high velocities, shear flows, and sharp corners. More information on these factors is discussed throughout the document, but the mechanisms of how multiple factors, individually and cumulatively, affect lamprey passage success will require more research.

It may be possible to improve the rates of passage success and decrease passage time for lamprey within salmon fishways with certain modifications, though even with modifications lamprey may find salmon fishways challenging. To assist those engineers, managers, biologists, technicians and mechanics designing, operating, maintaining and modifying fish passage facilities where lamprey must pass, this document compiles the available information on the upstream migration of adult Pacific Lamprey, and provides guidelines on how to improve lamprey passage in salmon fishways. These recommendations are based on information from both experimental fishway studies and monitoring passage at operational fishways, and are considered “best guidance” based on available information as of 2016. Note, however, that some fishways may present difficulties for lamprey passage that cannot be materially improved for lamprey passage without major structural modification.

Recommendations for lamprey-specific structures (“lamprey ramps” or lamprey passage structures (LPS); Moser et al. 2011) that capitalize on this species’ unique ability to climb near-vertical surfaces (“burst and attach” locomotion) are discussed briefly, and some case study examples are provided (Appendix A). For additional information and specific design criteria for LPSs, refer to Zobott et al. (2015).

3 SUMMARY OF RELEVANT BIOLOGICAL INFORMATION

3.1 Life History

Pacific Lamprey are anadromous: adults spawn in rivers, and their larvae rear in freshwater for up to 7 of years before migrating to the ocean as juveniles. As adults, lamprey return from the ocean to rivers to spawn; yet unlike salmon, lamprey do not home to natal streams. A detailed description of their life history is provided elsewhere (see Close et al. 2002; Clemens et al. 2010; USFWS and USFS 2010). For purposes of this paper, it is important to note that the life cycle of Pacific Lamprey requires safe migration corridors in rivers and tributaries for both upstream migrating adults and downstream migrating larvae and juveniles, although passage for downstream migration is outside the scope of this paper.

3.2 Swimming Speeds

The swimming speeds of Pacific Lamprey are considerably lower — less than half — the speeds of adult anadromous salmon species. Moser and Mesa (2009) summarized existing information on the swimming performance of adult Pacific Lamprey relative to other Pacific Northwest fish species (Table 1). Mean critical swimming speed for Pacific Lamprey was measured at 0.9 m/sec (2.8 fps; Mesa et al. 2003), although Moser and Mesa (2009) suggest this value should be considered conservative.

Bell (1991) found that adult lamprey can sustain swimming speeds of up to 0.9 m/ sec (3.0 fps), and burst speeds of up to 2.1 m/sec (7.0 fps) (Table 1). To illustrate the problems Pacific Lamprey face within salmon fishways, Pacific Lamprey burst swimming speed is near the orifice velocities typical of

many salmon fishways (2.1 - 2.4 m/sec or 7.0 - 8.0 fps; Table 2). These velocities, which can be encountered multiple times in a fishway, represent significant and recurrent challenges for adult Pacific Lamprey attempting to pass upstream. These challenges may be in terms of both immediate physical abilities (some weaker individuals may be excluded) and/or longer term energy costs that may reduce productivity and recruitment to the spawning population. For example, a Pacific Lamprey may initially enter a fishway and pass several obstacles, but ultimately tire and fall back without successfully passing upstream, thus potentially reducing significant energy reserves for gamete production and spawning activities.

3.3 Burst and Attach Locomotion

In addition to free swimming modes in the water column, Pacific Lamprey use “burst and attach” locomotion to move forward, allowing them to pass through some areas that have flows in excess of their free-swimming speeds (Reinhardt et al. 2008). Using their oral disc (“mouth”) to attach to substrate (attaching and resting phase), lamprey attach to rocks and other smooth, flat surfaces, and then undulate their body to move forward, and quickly reattach to the substrate (Reinhardt et al. 2008). Lamprey will repeat this process multiple times, with several resting periods in between, to move upstream, over, or around a passage impediment. This behavioral strategy requires adequate, smooth surfaces for attachment that allow successful suction-adhesion by the lamprey’s oral disc.

When adult Pacific Lamprey cannot swim through an area because of high velocities, they are forced to rely upon burst and attach locomotion. From the available research, it appears that adult Pacific Lamprey begin to use burst and attach locomotion when velocities reach approximately 0.60 m/sec (2.0 fps; Daigle et al. 2005; Table 1) and in areas of increasing turbulence and velocity (Kirk et al. 2016). Keefer et al. (2010) observed that velocities in the range of 2.4 - 3.0 m/sec (8.2 - 9.8 fps) likely exceed the abilities of Pacific Lamprey to use burst and attach locomotion. At 2.5 m/sec (8.4 fps), the burst and attach locomotion is inefficient, and lamprey passage is likely unsuccessful at flows with greater velocities (2.5 - 3.0 m/sec; Keefer et al. 2010; Kirk et al. 2016). Given large fishways in the Columbia River and multiple, frequent encounters with 2.1 - 2.4 m/sec (7.0 - 8.0 fps) at each weir orifice, there is concern about depletion of energy reserves for adult Pacific Lamprey that must repeatedly use burst and attach locomotion in these fishways (e.g., Kirk et al. 2015).

3.4 Climbing Behavior

Using burst and attach locomotion, lamprey are capable of ascending wetted surfaces that are near vertical to vertical under certain conditions, which can enable them to pass barriers and proceed upstream under some conditions (Reinhardt et al. 2008; Kemp et al. 2009). There must be enough flow over the lamprey to aerate its gills while using this behavior to climb, but they do not have to be completely under the water surface. In recent years, lamprey passage structures, or lamprey ramps, have been designed and installed to allow lamprey to use climbing behaviors to move upstream in cases where congregations of lamprey were observed (Moser et al. 2011, Zobott et al. 2015).

3.5 Lamprey Behavior in Fishways

Pacific Lamprey are most active at night (Moser et al. 2002; Daigle et al. 2005; Moser and Mesa 2009; Keefer et al. 2013b), especially within fishways where they encounter hydraulic and environmental complexities (Keefer et al. 2013a). Given the limited role of vision in lamprey navigation and their nocturnal migration, Kirk et al. (2015) hypothesized that behavioral guidance by adult Pacific Lamprey

primarily depends on hydraulic cues, and some tactile substrate cues are also used. Lamprey use visual and olfactory cues as well, particularly during the later phase of freshwater migration (Yun et al. 2011, Keefer et al. 2013b). With regards to their olfaction, it has been noted that passage of lamprey cease when a dead lamprey is lodged in a resting box of a lamprey passage ramp structure. Porter et al. (2017) theorized the presence of a dead lamprey is conspecific alarm cue, as an explanation for this behavior; however, additional research is needed to confirm this theory.

Adult Pacific Lamprey locate upstream migration routes following currents (positive rheotaxis). Adults are attracted by water volume and velocity have been shown to be important: sufficient flow volume is necessary to attract lamprey to fishway entrances, and the fishway flow must also have sufficient velocity to provide upstream migration cues at the entrance and each orifice (Moser and Mesa 2009; Keefer et al. 2010; Johnson et al. 2012; Kirk et al. 2015). To attract adult Pacific Lamprey to fishways, it is essential to provide a sufficiently large, but not excessive, attraction flow to bring lamprey to the fishway and minimize the energy expenditure required to successfully pass the entrance and continue up the rest of the fishway (Moser and Mesa 2009; Keefer et al. 2011).

Once in a fishway and provided a choice, adult Pacific Lamprey will preferentially use lower velocity channels with uniformly directed flow (Keefer et al. 2011), and areas of lower turbulence (Kirk et al. 2016). Thus it appears that Pacific Lamprey can select routes that reduce their energy expenditures if given the choice. Because of their dependency on hydraulic cues, consistent flow of appropriate velocity is needed to maintain guidance through a fishway. For example, lamprey were shown not to use submerged orifices in transition areas that had no velocity (Moser et al 2002b, Keefer et al. 2013a). Similarly, in flow transition zones where velocity cues can be near-zero, or in turbulent or changing flow patterns that could be confusing to lamprey, they have been shown to turn around and exit the fishway, moving downstream (Keefer et al. 2013a, Kirk et al. 2015). Radio-telemetry studies have shown that these lamprey that “fall back” seldom attempt to pass upstream again (Keefer et al. 2013a). Some work at the lower Columbia USACE dams has shown that providing “refuge boxes” will help retain lamprey in the ladders, because the refuge boxes provide cover during daylight hours (Corbett et al. 2013, 2014, 2015; Refuge Box Case Study (Bonneville)).

Lamprey are demersal, and typically migrate within fishways near the floor and walls (Keefer et al. 2011; Keefer et al. 2010; Moser and Mesa 2009), especially when confronted with high velocity and high turbulence where they may need to employ burst and attach locomotion to move forward or rest (Kirk et al. 2016). Recent research at fishways at Bonneville Dam found free-swimming Pacific Lamprey distributed throughout the water column and mid-channel, suggesting that they alter their swimming mode in response to multiple environmental conditions (Kirk et al. 2015). In particular, at Bonneville Dam, it was noted that reduced velocities within the fishway, attraction flows at the entrance in the upper water column, limited turbulence, and presence of White Sturgeon (*Acipenser transmontanus*) in the lower water column were factors hypothesized to influence lamprey distribution and cause them to move away from the floors and walls of the fishway (Kirk et al. 2015). Under these circumstances, lamprey employed free-swimming (without tactile substrate cues) to locate the attraction plume, and thereby avoid the benthically-oriented sturgeon (Kirk et al. 2015).

Lamprey appear to readily move through fishways when velocities are less than 1.2 m/sec (3.9 fps; Keefer et al. 2012). At higher velocities, lamprey switch to burst and attach locomotion to overcome difficult passage conditions (high velocity and high turbulence areas). This behavior likely provides

some resting opportunities (Kemp et al. 2009; Kirk et al. 2015). Both extended and repeated bouts of burst swimming and movement through highly turbulent areas appear to exert a high physiological cost (Kirk et al. 2016). In circumstances where burst and attach locomotion is used, the presence of continuous surfaces for attachment (rounded corners at entrances/orifices, or ramps at steps/sill blocks, etc.) may facilitate successful upstream movement.

The sustained swimming speed of lamprey is conservatively hypothesized to be ~0.9 m/sec (~3.0 fps) (Table 1), although Keefer et al. (2013b) suggests lamprey were able to pass 1.2 m/sec. For the purposes of this document, we are assuming 0.9 m/sec (~3.0 fps) is an appropriate free-swimming, maximum velocity for fish passage designers to use to accommodate Pacific Lamprey in fishways. Above 1.0 m/sec (3.3 fps), some adult lamprey switch to burst and attach locomotion. It should also be noted that there are large variations in swimming ability within a species, because of relative size, condition, temperature, and even temperament (Moser et al. 2013). Reduced physiological capacity and seasonal changes in temperature or tailrace conditions may also contribute to observed seasonal shifts in passage “bottlenecks” (Keefer et al. 2013a), where areas of passage difficulty shifted over the migration period, which further complicates our ability to understand passage needs for Pacific Lamprey at a particular location.

The following sections discuss the different types of fishways, the areas within fishways that are problematic for adult Pacific Lamprey and why, and proposes recommendations to address these problems and improve lamprey passage. These recommendations are based on our limited understanding and may be updated, and in some cases, altered as more research occurs.

TABLE 1. Lamprey swimming abilities and behaviors relative to water velocities.		
Parameter	Speed	Source
Sustained swimming speed ¹	0.9 m/sec (3.0 fps)	Bell (1991) ⁴
Critical swimming speed ²	0.9 (+/- .075) m/sec 2.8 fps (+/- 0.25) fps)	Mesa et al. (2003) Moser and Mesa (2009) estimate “conservative”
Burst swimming speed ³	2.1 m/sec (7.0 fps) >80% passage for 2.4 m/sec (7.9 fps) in lab tests- (thus length of sustained burst and presence of turbulence interacts with velocities)	Bell (1991) ⁴ Kirk et al. (2016)
Free-swimming abilities	<1.2 m/sec “Lamprey more readily moved through sections where water velocity was ≤ 1.2 m/sec (3.9 fps), below the estimated burst swim speed for adults.”	Kefer et al. (2011) Kefer et al. (2012)
Barrier: Head differential	Slot entrance with > 0.4 m (1.5 feet) head – may eliminate passage	Kefer et al. (2010)
Behaviorally-lamprey change to burst and attach locomotion	>0.6 m/sec (~2.0 fps)	Daigle et al. (2005)
Burst swim speed and burst and attach locomotion exceeded	2.5 - 3.0 m/sec (8.2 - 9.8 fps)	Kefer et al. (2010); Kirk et al. (2016)
Attach and burst locomotion “ineffective”	When velocities exceed burst swim speed (2.1 m/sec (7.0 fps)) or confusing stimuli guide fish to impassable areas	Moser et al. (2009)
Exclusion Grating	Open space ≤ 1.9 cm (0.75 inches) for new migrants entering the Columbia River, as determined at Bonneville Dam. At other locations, reduced gap size is likely needed because lamprey shrink over time. Pacific Lamprey in the upper Columbia Basin, and perhaps other drainages, are probably smaller and could get through this gap size.	Moser et al. (2008) Moser, pers. comm. (2016)
Climbing abilities	Able to climb vertical or near vertical surfaces when appropriate attachment surface is provided, and can use climbing behaviors to move past areas with high velocities.	Reinhardt et al. (2008) Kemp et al. (2009) Moser et al. (2009)

FOOTNOTES (Table 1)

¹ *Sustained swimming speed*: The maximum swimming speed at which a fish can swim almost indefinitely (traditionally defined as > 200 minutes) without stopping or fatiguing. This metric of swim performance is often measured under controlled laboratory conditions, using established procedures (Beamish 1978).

² *Critical swimming speed*: The maximum swimming speed at which a fish can swim for a limited amount of time before fatiguing (traditionally defined as 20 s – 200 minutes). This swimming speed is faster than the sustained swimming speed, but slower than the burst swimming speed. This metric of swim performance is often measured under controlled laboratory conditions, using established procedures (Beamish 1978).

³ *Burst swimming speed*: The maximum swimming speed at which a fish can swim for only a very brief amount of time (traditionally defined as < 20 s) before fatiguing. This swimming speed is faster than both critical and sustained swimming speeds. This metric of swim performance is often measured under controlled laboratory conditions, using established procedures (Beamish 1978).

⁴ Information consolidated by Bell (1991) does not provide specific information on species, size of fish, or methodologies used to determine the sustained swimming speed, and thus should be used with caution.

TABLE 2. Typical velocities encountered in upstream fish fishways designed for salmonids.		
	Velocities	Notes
Entrance	2.1 - 3.0 m/sec (~7.0 – 10.0 fps)	Velocities exceeding burst swimming speeds; likely a significant deterrent or barrier.
Submerged orifice with 0.31 m (1.0 foot) head differential	1.8 - 2.4 m/sec (6.0 - 8.0 fps)	Velocities approaching and exceeding lamprey’s burst swimming speeds; lamprey may have to resort to burst and attach locomotion, but may tire with successive attempts.
Submerged orifice with 15 cm (6 inches) head differential	1.2 - 1.8 m/sec (4.0 - 6.0 fps)	Lamprey more readily move using free-swimming through these velocities (especially at the lower end of the range), and would likely have to use burst and attach locomotion less.

4 TYPES OF SALMON FISHWAYS

There are several different types of commonly constructed fishways for upstream migrating salmonids. Common types of fishways include:

1. Pool and weir fishways (including Ice Harbor, half Ice Harbor, which often have both submerged orifices and overflow weirs to connect adjacent pools. Some pool and weir fishways have only submerged orifices or only overflow weirs; Figures 1 and 2).
2. Vertical Slot fishways (have a tall, narrow orifice that extends from the floor to the water's surface; Figure 3A). Serpentine fishways — an uncommon variant of vertical slot fishways where the slot is an elongated channel — may make lamprey passage more difficult (Clabough et al. 2009; Keefer et al. 2010; Keefer et al. 2012; Keefer et al. 2014) than other types of fishways (Figure 4).
3. Pool and chute fishways (a pool-and-weir variant with wide, sometimes full channel, overflow weirs with capability of higher flows (useful for fish attraction) than other fishway types; often include submerged orifices (Figure 5).

In general, salmon fishways consist of a series of sequential pools that gain elevation with each pool. Each pool is separated by some type of weir or constriction (e.g., vertical slots). In many salmon fishways, each weir has an overflow section (surface weir; Figure 1), and often also a submerged orifice at or near the floor level² (Figure 2). If both surface weir and submerged orifice are present, fish may pass either route. Submerged orifices may be flush with the floor, or located above the floor (like a window in a wall) and have a step (Figure 2). Other fishways (such as vertical slot and serpentine fishways) have a narrow, vertical slot opening that functions as a passage route from pool to pool: this slot is usually continuous from the water surface to the floor, but may have a “step” or sill block at the floor (Figures 3A and 3B).

Upstream migrating fish enter these fishways at the downstream end of the fishway (the fishway entrance). A fishway entrance often has several components:

- An attraction jet/flow exiting the entrance to assist fish in locating the fishway. This jet may be enhanced (above normal fishway flow), using an auxiliary water supply system (described below). In some fishways, the volume and velocity of added attraction flow is adjustable.
- Auxiliary water supply refers to water that is added or manipulated to adjust hydraulic conditions (head or flow) within a fishway. The auxiliary water supply often increases the volume of water relative to the overall fishway flow to supplement the fishway attraction jet at the entrance, and provide sufficient volume relative to other competing flows at the barrier (spill, turbine outflow, etc.). Auxiliary water supply inputs may or may not be near the fishway entrance.
- Diffuser grating (exclusionary grating usually associated with the location where auxiliary water is added) to exclude fish from ascending inappropriate, dead-end, or unsafe routes within the fishway). Diffuser grating is often located immediately above or near the entrance, but water may be added at various locations throughout a fishway.

² In areas where there is insufficient flow the orifices may not be employed, because they would dewater the ladder at lower flows.

- Bulkhead isolation slots are adjusted to allow fish access, manage discharge volume and/or head, and isolate a fishway to dewater for maintenance.

Other typical fishway components may include:

Transition Areas are used to link different sections of the fishway. These include collection channels and junction pools, and these areas are often located at the upper and lower sections of a fishway to allow for fluctuating forebay and tailrace water levels (Keefer et al. 2012).

Counting Windows: Some fishways have lighted counting windows that allow for the enumeration of fish moving upstream. There is typically a crowding of the fish to one side of the fishway to ensure fish are close enough to the window to be viewed clearly. This crowding is often accomplished with picket leads that guide the fish to the window. There may also be a ramp that guides the fish up into the viewable area of the counting window as most windows are raised off the floor and do not span the entire height of the fishway wall.

Fishway Exits allow fish to exit a ladder and enter the upstream reservoir or stream and may either be open channel exits or orifices. Typically a portion of the flow of the fishway enters at the exit, on the upstream end. At projects that have a wide range of reservoir elevations, there can be multiple fishway exits at the downstream dam that operate at different reservoir elevations. Such exits require multiple gates and other facilities that can create complex management issues.

5 LAMPREY PASSAGE IN SALMON FISHWAYS

From the research to date, high velocity and turbulent areas with limited or insufficient surfaces for oral disc attachment by Pacific Lamprey generally describe the majority of passage impediments to lamprey. Recent studies have shown that within fishways, multiple factors interact to affect passage success of adult Pacific Lamprey. Areas of combined high velocities and turbulence over long distances are the most difficult for lamprey to pass (Kirk et al. 2015, 2016). Long distances (~80 m or ~260 feet) where lamprey were swimming at or near critical swimming speed may exceed their energetic capacity, resulting in failed passage (Kirk et al. 2015). The primary hydraulic challenges, which may have cumulative or even synergistic effects on the passage success and physiological condition of adult Pacific Lamprey, were summarized by Keefer et al. (2012):

- Velocities
 - 2.5 - 3.0 m/sec (8.2 - 9.8 fps) exceeds burst swimming abilities and substantially inhibits (e.g., likely blocks) lamprey passage.
 - Lamprey more readily moved with free-swimming in velocities < 1.2 m/sec (3.9 fps), which exceeds, but is close to sustained swimming abilities.
- Distance
 - Lamprey encountering difficult passage conditions for extended distances are more likely to fail to pass, especially in areas without adequate resting areas or limited attachment surfaces.

- Shear flows³
 - No quantitative evaluations on lamprey currently exist, but these types of flows are considered to be problematic because lamprey can be swept downstream as they move into shear flows, particularly when using burst and attach locomotion.
 - Pacific Lamprey do not have the swimming abilities to overcome high-velocity, shear flows, especially if they are positioned perpendicular to the flow and have no area of attachment.
 - Problem sites include weir orifices, sites requiring Pacific Lamprey to employ burst and attach locomotion with elevated or recessed steps (non-planar surfaces), some fishway corners, and serpentine weirs.
- Turbulence
 - Often coincides spatially with high velocities and shear flows.
 - Limited quantitative evaluations exists for how turbulence affects Pacific Lamprey passage, but hypothesized to be prohibitive for adult Pacific Lamprey attempting to use pass dams.
 - Sites where turbulence can occur include serpentine weir sections, fishway corners and turn pools, some submerged orifices, fishway entrances (especially adjacent to fishways), diffuser areas, and flow disrupters placed on fishway floors.

The following sections describe common components of salmon fishways, why these components are problematic for adult lamprey passage, and potential solutions to improve passage efficiency for lamprey. The sections are generally ordered from downstream to upstream. Table 3 provides an overview of recommendations and modifications to adult salmon fishways to improve passage for adult Pacific Lamprey.

5.1 Attraction Flows and Entrance Conditions

Salmon fishway entrances typically use either a submerged orifice or an open channel entrance, or both, before transitioning into the ladder segments. At large fishways, substantial volumes of water are used to create a relatively extensive, uniform, attraction “jet” at the entrance that can be located by Pacific Lamprey migrating upstream, and to guide them away from other areas of discharge (spillways, turbines), and to the fishway entrance. The flow volume of the attraction jet is typically sized as a percentage of other competing discharges (i.e., spillway flow, turbine discharge, etc.). The large volume of the attraction jet (as distinguished from high velocity flow) is important for both salmonids and lamprey for detecting fishway entrances (Moser and Mesa 2009; Keefer et al. 2010). For example, entrance efficiency of adult Pacific Lamprey at a fishway near the powerhouse at Willamette Falls was higher when all turbines were on, versus when they were off (Moser and Mesa 2009). Keefer et al. (2010) found adult Pacific Lamprey did not locate or enter an experimental fishway with near-zero velocities.

Entrance velocities are typically 2.1 – 3.0 m/sec (7 – 10 fps)⁴ and fishway operations target 0.3 – 0.5 m (1.0 – 1.5 feet) head differential (Table 2). These conditions create entrance velocities that

³ In this discussion, the term “shearing flow” is used to refer to areas where water velocity changes abruptly in direction or amplitude (e.g., the transition zone between a sheltered, low velocity area --behind a rock or structure, for example--and a much higher velocity flow of water immediately adjacent to that rock or shelter.

are at or in excess of the burst swimming speed of Pacific Lamprey (Table 1). Such conditions are challenging for Pacific Lamprey to overcome, especially if turbulence and or localized higher velocity areas are inadvertently created. However, lamprey may be able to pass through this high velocity jet and enter a fishway using burst speeds over relatively short distances, or using burst and attach locomotion (Kirk et al. 2016). In a recent experimental fishway study, the majority of Pacific Lamprey (more than 80%) were able to pass velocities of 2.4 m/sec (8.0 fps) for short distances (≤ 0.6 m [2.0 ft]), but passage success was reduced when the slot length was increased to 1.0 m (3.0 ft; Kirk et al. 2016). However, a portion of the population (smaller, “weaker” swimmers, those nearing spawning with reduced energetic capacity) may not be able to successfully pass through the entrance. Thus, there is a need to balance sufficiently large attraction while simultaneously minimizing energy expenditure for lamprey attempting to enter the fishway (Moser and Mesa 2009; Keefer et al. 2010; Johnson et al. 2012).

RECOMMENDATIONS: For existing fishways, reducing velocities through operational changes (Section 6.1.1), and/or physical modifications to the entrance (Sections 6.1.2 and 6.2 – 6.4) may be implemented either individually or in combination, depending on the situation. Operational changes could be done primarily at night (when most lamprey migrate and most salmon are less active), especially if such changes may negatively affect salmonid passage. More than one fix may be needed to substantially improve lamprey passage. The physical modifications may apply to conditions at entrances, orifices, weirs and exits, so each modification is discussed in its own section.

5.1.1 Operational Changes at Entrances

Some operational changes may reduce velocities and head differentials sufficiently at a fishway entrance to improve passage efficiency of adult lamprey while maintaining adequate attraction for them. For example, operational tests at Bonneville Dam fishways, in which velocities and head differentials were reduced at nighttime when lamprey were active (and salmon were less active), increased the entrance efficiency of adult lamprey. These operational changes at Bonneville Dam proved to be a low-cost, effective tool that did not impact upstream salmon passage (Daigle et al. 2005; Johnson et al. 2012). Reduced velocities (e.g., ~1.2 m/sec [3.9 fps] relative to 1.9 m/sec [6.2 fps]) were shown to improve lamprey entrance efficiencies in both experimental fishways and large fishways (Daigle et al. 2005, Johnson et al. 2012). While these modified operations were somewhat beneficial and increased entrance efficiency, these improvements were relative, and did not result in passage success rates similar to those documented for salmonids. Even with these improvements to salmonid fishways, lamprey may have great difficulty in passing these fishways. Thus, some physical modifications (Sections 6.2 - 6.4) or other improvements (either at the entrance or throughout the fishway) should be considered.

RECOMMENDATIONS: Where feasible (i.e., in situations that will not materially affect competing needs, such as salmonid passage), reduce auxiliary water supply at night to minimize

⁴ NMFS (National Marine Fisheries Service). 2011. Anadromous Salmonid Passage Facility Design. NMFS, Northwest Region, Portland, Oregon. See 4.2.2.4 Hydraulic Drop: The *fishway entrance hydraulic drop* (also called entrance head) must be maintained between 0.30 - 0.46 m (1.0 - 1.5 feet), depending on the species present at the site, and designed to operate from 0.15 - 0.6 m (0.5 - 2.0 feet) of *hydraulic drop*.

impacts to migrating salmon. Reducing entrance velocities to below 1.2 m/sec (3.9 fps) should maintain sufficient attraction volume for lamprey, while allowing them to free-swim through the entrance.

5.1.2 Physical Modifications to Entrances

Operational changes may not be sufficient on their own, and physical modification at a fishway entrance may be necessary. The physical entrance of the fishway, in combination with high velocities, may have several components that lack adequate attachment surfaces for lamprey to use burst and attach locomotion, including entrance orifices with sharp angles and corners, bulkhead slots, and diffuser gratings. When velocities are too high for lamprey to swim through, and no continuous attachment areas are available for them to use burst and attach locomotion, lamprey are not able to effectively or efficiently pass into the fishway. Problematic features may occur at entrances or other locations within the fishway; recommendations are discussed throughout the following sections.

The USACE has made modifications to entrances at Bonneville Dam at Cascade Island to benefit lamprey passage (Clabough et al. 2015). Entrance modifications included installation of a variable width entrance weir, which is designed to improve attraction flows for salmonids in the upper portion of the entrance (which is narrower) and to reduce velocities near the bottom (which is wider) for lamprey passage. Modifications also included placement of bollards along the floor to reduce velocities and elimination of lower bulkheads that may have interfered with passage of lamprey. Subsequent evaluations of lamprey passage comparing passage metrics pre- and post-modification have been mixed: entrance efficiency improved, but more lamprey exited back into the tailrace and had longer travel times after modifications were completed (Clabough et al. 2015).

5.2 Corners/ Sharp Angles

Lamprey can be hindered by squared corners or sharp edges (e.g. 90° angles) in areas of high velocities where they need to use burst and attach locomotion because these sharp angles do not allow them to quickly re-attach to a flat surface after burst swimming. Even seemingly small but abrupt edges that disrupt a continuous flat area can prevent forward movement by lamprey, and cause them to fall back downstream in high velocity areas. Examples of these areas include corners at entrances and weir orifices, orifices with steps (orifices not flush with floor), overflow weirs, bulkhead slots, and stop log guide slots.

RECOMMENDATIONS: To allow lamprey to use burst and attach locomotion, continuous planar areas for attachment are needed as velocities begin to increase above ~1.0 m/sec (~3.3 fps); as turbulence increases, continuous planar areas may be needed at velocities less than 1.0 m/sec (3.3 fps). Orifices (or slots) should be located along a planar surface (e.g., along the floor without a step; Figure 2). For existing fishways with perched orifices (orifices with a step or sill block), the addition of 3 : 1 ramps on the downstream side of the orifice provides a route of passage over the step/sill block and provides a continuous attachment along the floor (Figures 3A and 3B). It may be beneficial, but unknown at this time, whether providing a ramp on the upstream side of the orifice is necessary to allow the lamprey to maintain attachment until out of the high velocity area. Locating the orifices in the corner of a weir will provide a continuous

attachment surface along both the floor and the wall, which provides more attachment opportunities for lamprey (Figure 2).

Rounded corners (8 to 10 cm [\sim 3-4 inch] radii or greater) at the orifice walls are advised at velocities above 1.0 m/sec (3.3 fps), on both the up- and down-stream side of each wall (Figure 2). Keefer et al. (2010) found improved passage success when bulkheads were rounded with a 20.5 cm (8.4 inch) diameter circle. Rounding the orifice walls at an existing fishway can either be accomplished via cutting/rounding the wall, or installing inserts around the wall (Figure 6) that create a smooth, continuous and rounded surface for lamprey to pass using burst and attach locomotion. Rounded corners may not be required where velocities are less than 1.0 m/sec (3.3 fps), in which case lamprey are likely to free-swim in the water column. In some instances, chamfered corners at the orifice walls have been used to improve lamprey passage (See Case Study at River Mill Dam); however, no studies have directly tested lampreys' ability to use chamfered corners relative to rounded corners.

5.3 Bulkhead Slots/Stop Log Guides

To isolate and dewater the fishway for inspection, maintenance and repairs, and other purposes, fishways typically have bulkhead gates or stop logs at the entrance and exit. These features unfortunately create discontinuities that are problematic when lamprey attempt to pass using burst and attach locomotion. These gates are held in place with slots, which are built into the sides and bottom of an orifice/entrance to support the gate when closed (Figure 6). When the gates are raised, the slots create a gap in the continuous surface of the orifice wall, and can prevent lamprey passage in high velocity areas. Stop log guide gaps may also be in overflow weirs. Some fishways have metal frames to hold bulkheads or stop logs, which can also create non-planar surfaces that prohibit burst and attach locomotion (Figure 6).

RECOMMENDATIONS: In some dams in the Columbia and Willamette basins, "inserts" have been added to eliminate the slot or gap when the gates/stop logs are not in place (Figure 6). When designing inserts, care should be taken to ensure the insert creates a smooth continuous surface with no gaps or abrupt surface changes (bumps) in the transition between the fishway wall and the insert. In another situation (new construction), the entrance gate was designed so there were no slots along floor or lower walls of entrance, and the gate did not need the slots to function (See Case Study Willamette Falls Fishway).

5.4 Diffuser Grating for Attraction Water Supply

Salmon fishways often add water into the lowermost fishway section, to provide attraction away from other non-passage discharges (i.e., spillways, turbines), and into the fishway. This additional volume of water is often introduced through floor or wall gratings (diffusers) in the lower part of the fishway, just upstream of the entrance and lower fishway sections (Figures 7A and 7B). Criteria for salmon fishways require the velocity coming through the diffusers to be lower than the prevailing current within the fishway. To create these low velocities through the diffusers, diffuser gratings often cover large areas of fishway floors and walls. This situation can cause the following problems:

- Adult lamprey will potentially be attracted to swim through the grating into the auxiliary water supply because it might appear as a lower velocity route of passage, resulting in their passage delay, injury, or perhaps even death.

- Creation of a partial or complete passage barrier in high velocity areas where lamprey would otherwise be able to pass using burst and attach locomotion because diffuser grating does not provide continuous attachment surfaces (e.g., see Daigle et al. 2005).
- Flow from diffusers may create confusing cues to lamprey and result in increased passage times, or “turn-arounds,” in which lamprey reverse direction and move back downstream instead of continuing to move up the fishway (Keefer et al. 2011, 2012; Moser et al. 2008).

RECOMMENDATIONS: To prevent lamprey from entering undesirable areas, all diffuser grating should have ≤ 1.9 cm (~ 0.7 inches) open space between bars (see 5.12.3 Picket Leads; Moser et al. 2008). Diffuser grating would ideally be used only along the upper walls of the fishway, not along the floors or the lower walls (Figures 7A and 7B). Anecdotal observations suggest that lamprey often attach to the floor or wall/floor interface; thus we suggest that grating would not be placed on the floors or lowermost 0.3 m (1.0 ft) of the walls. This would allow lamprey continuous passage along the floor and lower walls, and may reduce confusing flow patterns along the floor of the fishway. Omitting diffuser gratings from the floors and lower walls of a fishway would also minimize the potential for stranding fishes when dewatering the fishway for maintenance and inspections.

Diffusers located in high velocity areas (≥ 1.0 m/s, 3.3 fps),

- Wall diffusers: should be elevated off the floor by at least 0.3 m (1.0 ft).
- Floor diffusers:
 - Should be located at least 1 m (3.3 ft) above and below (e.g., horizontally) weir orifices, if they cannot be avoided in new construction.
 - To provide a continuous attachment surface where existing floor diffuser grating is necessary, a flat metal plate (minimum width of 0.3 m [1.0 ft]) can be used to span diffuser floors and provide attachment areas (Keefer et al. 2010; Figures 7A and 7B). This may be important above and below orifices and entrances where velocities require that lamprey use burst and attach locomotion to pass, in areas where there is increased turbulence and confusing hydraulic cues, or in areas where the combined distance, turbulence and velocities are such that lamprey may need to attach to rest.

If floor diffusers in new construction cannot be avoided, diffuser grating should not be located in the first 0.31 m (1.0 foot) of floor next to the wall and the lower 0.3 m (1.0 foot) of the wall, and diffuser grating should not be placed immediately upstream or downstream of localized high velocities, (such as a fishway entrance or submerged orifice), where lamprey may need to attach to pass or rest (Figures 7A and 7B).

5.5 Resting Areas/Refuge Boxes

For lamprey traversing a salmon fishway, resting opportunities may be critically important (Daigle et al. 2005; Keefer et al. 2011; Kirk et al. 2016). The lack of resting areas for adult Pacific Lamprey increased their passage time, and likely their energetic expenditures as well (Daigle et al. 2005). The USACE has also provided “refuge boxes” within fishways to provide dark, low velocity areas for lamprey to hold in during the day and rest, when they normally seek out dark areas (Corbett et al. 2013, 2014, 2015; Figure 8). Monitoring the use of these boxes

with PIT tags has shown that a substantial portion of lamprey are seeking out and using these refuges during the daylight hours, and that these refugia appear to reduce the number of lamprey that fall back. Additional monitoring is needed to better understand the impact of such refuges on overall passage success.

RECOMMENDATIONS: The addition of resting areas for lamprey is important for passage, particularly as fishway length, elevation gain or ascent distance increases (Daigle et al. 2005; Keefer et al. 2011). Resting opportunities should be available at regular intervals throughout a fishway. Each resting area for adult Pacific Lamprey in fishways should provide areas of relatively low velocity (e.g., 0.9 m/sec or less) and darkness, with natural substrate, such as the refuge boxes developed by Corbett et al. (2013; Refuge Box Case Study (Bonneville); Figure 8). These refuge boxes may prove particularly helpful in problematic areas where lamprey have been shown to fall back out of the fishway.

5.6 Attachment Surfaces

Moser and Mesa (2009) suggested that the best surfaces are “smooth and non-porous,” such as glass and polished metal, but noted that lamprey can and do attach to roughened, wetted concrete. Generally, the surface must allow the oral disk of the lamprey to create a reliable seal. Thick algal growth can inhibit climbing on angled climbing surfaces (M. Moser, pers. comm. 2016). In the Columbia River Basin, aluminum has been used successfully in lamprey passage structures (LPS or ramps; Moser et al. 2011). There is some indication that lamprey use of ramps increase as the material ages and a thin biofilm develops on the surface. The cause of increased use is unknown, but it was hypothesized that the aging process reduced presence of repellent olfactory cues that occur on newly installed aluminum (Moser et al. 2011).

RECOMMENDATIONS: For modifications that require inserts (i.e., bulkhead slots, rounding sharp corners, ramps), flat plate aluminum may be used to provide a smooth continuous surface for lamprey passage. Aging the structure after construction may be beneficial. To create floor ramps for lamprey to pass orifices with steps or sill blocks, concrete could be placed, formed, and smoothed. For any new or modified structure to improve lamprey passage, care should be taken to ensure a smooth continuous surface with no gaps or abrupt surface changes (bumps) in the transition areas. Even seemingly small abrupt gaps may inhibit or block successful passage if in an area where burst and attach locomotion must be used (i.e., climbing, shear zones, or high velocities). Surfaces such as smoothly painted surfaces, plastics, glass, and concrete may also provide adequate attachment surfaces. Surface irregularities should be minimized and likely not exceed 2 mm (0.08 inch), based upon anecdotal observations (Mary Moser, pers. comm. 2016). Adams and Reinhardt (2008) found that surfaces with narrowly spaced grooves of 1 mm (0.04 inch) width and 3 mm (0.12 inch) depth prevented Sea Lamprey (*Petromyzon marinus*) from maintaining attachment.

5.7 Collection Channels

Collection channels are common features at larger dams, and are characterized by relatively non-turbulent flow, although sometimes there are diffusers with upwelling flow (Keefer et al. 2012). Passage studies for Pacific Lamprey conducted at large dams on the Columbia River have found that although lamprey can generally move through these lower velocity collection channels (Clabough et al. 2010b; Keefer et al. 2012), many lamprey will exit these areas and return to the

tailrace (“fall out” or “turn arounds”). The mechanisms affecting lamprey passage in these areas are not well understood, but Keefer et al. (2012) hypothesized the first submerged weirs inside the fishway at the terminus of the collection channel (determined by the tailwater elevation) may negatively affect passage due to the lack of clear hydraulic cues and/or attraction flow. Other factors that may be affecting passage in the collection channels include hydraulic changes associated with multiple fishway openings along the collection channel and the presence of sturgeon in these channels.

RECOMMENDATIONS: Generally, there is insufficient data here to determine a “best recommendation” for these. Assuming the problem with collection channels is associated with hydraulic cues and attraction, new construction should incorporate features to better maintain uniform hydraulic flow for lamprey along the floor, while still providing opportunities for resting. The use of refuge boxes in these areas where lamprey have higher rates of fall out may prove useful (see section 6.5 Resting Areas; Refuge Box Case Study (Bonneville); Figure 8).

For existing or new construction, alternative routes that bypass the collection channel (or portions of it) using lamprey passage structures (ramps) could also be used if conditions and behavior suggested ramps might be successful.

5.8 Junction Pools and Transition Pools

Junction pools are where two or more fishway components join together (e.g., where multiple collection channels meet; Keefer et al. 2012). Transition pools are typically used to describe the fishway sections where submerged weirs transition to overflow weirs, and have features common to both fishways (weirs, orifices) and junction pools (reduced velocities, greater depth; Keefer et al. 2012). While some of these areas have been shown to be difficult areas of passage for lamprey, the mechanisms of passage failure are not well understood (Keefer et al. 2012). Failed passage within these areas may result from low attraction or confusing hydraulics, velocity barriers, various structural challenges (grating, vertical steps inside submerged orifices, recessed floor segments), and high densities of predatory White Sturgeon (Kirk et al. 2015). As an example of a recent modification for existing fishways, the USACE removed two overflow weirs at John Day Dam (north fishway entrance area) to increase attraction velocities in a transition area in conjunction with several other entrance improvements (Clabough et al. 2015). Subsequent evaluations on passage metrics suggest the combined modifications provided good passage conditions.

The extent of the effect of these transition areas on lamprey passage can vary with water level fluctuations within the tailrace, as more or less of the pools are inundated. The following quotation summarizes our understanding of lamprey passage in transition pools: *“Notably, many lamprey that successfully pass through transition pools do so without long passage delays. It is possible that these fish used different routes (i.e., along the walls versus along the fishway floor versus over overflow weirs) than those that turned around in the pools, or that they approached during favorable tailwater or operational conditions, or periods of lower predator density”* (Keefer et al. 2012).

RECOMMENDATIONS: New construction should ensure there are sufficient hydraulic cues for fish to continue upstream, and incorporate features to better maintain uniform hydraulic flow

for lamprey along the floor in these pools, while maintaining sufficient resting areas. Placement of refuge boxes as discussed above could provide such resting areas (see Section 6.5 Resting areas; Refuge Box Case Study (Bonneville); Figure 8). For existing or new construction, alternative routes that bypass these pools using lamprey passage structures (ramps) could also be used if conditions and behavior suggested ramps might be successful.

5.9 Temperatures in Fishways

Increased water temperatures can affect lamprey migrations and potentially become a barrier. A combination of laboratory and field tests and field observations in the Willamette River Basin suggest that warm summertime temperatures (greater than or equal to 20°C) during July-August affect lamprey migrations, maturation and survival (Clemens et al. 2009, 2016). Clemens et al. (2012, 2017) found that summertime stream temperatures were correlated with slowing of the upstream migration, and in some cases, ceasing of upstream movement. Keefer et al. (2013a), as stated above, noted that seasonal changes in temperature may also contribute to observed seasonal shifts in passage “bottlenecks.” Thus, while temperature has effects on lamprey passage in fishways, these effects are poorly understood and may complicate our ability to evaluate lamprey passage.

RECOMMENDATIONS: In fishways where temperatures reach 20°C or more when adult lamprey are actively migrating, inputs of cooler water from an upstream source (if available) should be added to the fishway to reduce the water temperatures. Use of shade cloth or similar material over the fishway should be used to lessen solar radiation effects and reduce warming.

5.10 Predation associated with Fishways

Pacific Lamprey are a natural prey item for many native species, such as White Sturgeon, river otters, seals, sea lions, and blue herons. In some situations, fishways can create conditions or areas that concentrate upstream migrating adult lamprey, making them more susceptible to predators than might occur in natural riverine habitats. These areas include the tailrace areas near fishway entrances, entrance and exits of fishways, and within the fishways themselves. As previously discussed, high densities of sturgeon at Bonneville Dam may cause lamprey to alter their behaviors or fail to pass (Kirk et al 2015).

Fishway entrances, exits and collection channels create localized areas in which a predator can ambush upstream migrant fish as they attempt to negotiate the fishway. It is well documented that White Sturgeon, seals and sea lions prey on anadromous salmonids and lamprey at fishways like Bonneville Dam on the Columbia River (Madson and Van der Leeuw 2016, Tackley et al. 2008). River otters can also hunt within fishways, where there is no cover for lamprey to hide and avoid predation. In certain conditions (e.g., ramps, shallow fishways such as certain areas at Willamette Falls), blue heron are more easily able to find and prey upon adult lamprey, because of the lack of cover on these artificial passage structures.

RECOMMENDATIONS:

Reducing the access and opportunities of potential predators should be considered when developing fish passage opportunities for adult lamprey. Some actions that have been used

include reducing predator access (e.g., Sea Lion Exclusion Devices), acoustic deterrent devices and hazing to frighten predators away (Madson and Van der Leeuw 2016, Tackley et al. 2008). River otters are too similar in size of salmon to be excluded from a fishway; installing barriers/fencing to limit overland access into the fishway or refuge boxes to provide lamprey cover from predation may reduce predator opportunities, but removal by trapping may ultimately be necessary if predation is a significant problem. Installation of ropes, wires, or flagging may physically deter avian predators, such as herons. Sprinkler systems may help provide cover from terrestrial predators by breaking up the water's surface to reduce visibility, and if possible, providing natural substrate (i.e., large cobbles) to provide refuge from predators.

5.11 Weir Sections

5.11.1 Overflow Weirs/ Submerged Orifices at Salmon Fishways

Many salmon fishways have both overflow weirs and submerged orifices, which create localized areas of high velocity and turbulence. Most salmonid fishways were designed with 0.3 m (1.0 foot) elevation difference between pools, which results in around 2.1 – 2.4 m/ sec (7.0 – 8.0 fps) jets through the orifices and overflow weirs. Because of their demersal behavior, lamprey are more likely to use the submerged orifices, although they are also observed to use overflow weirs (Keefer et al. 2012). In both instances, lamprey primarily appear to pass these areas using burst and attach locomotion; these areas do not appear to be a passage impediment because the areas of high velocity are relatively short (0.3 – 0.6 m (1.0 – 2.0 feet)), and the pool immediately above the weirs typically provides resting opportunities.

RECOMMENDATIONS: For submerged orifices, continuous planar floor surfaces should be provided for lamprey attachment until outside of the high velocity area of the orifice (Keefer et al. 2012; approximately 1.0 m [3.3 feet] upstream and downstream of an orifice or weir), via making orifices flush with the floor (no steps) and/or flush to the outside fishway wall (Figure 2). If at least one continuous planar surface is provided, (i.e., the floors), then rounded corners may not be needed at the actual orifice. For fishways with existing steps at orifices, ramps can be added on the downstream side of the orifice to allow for burst and attach locomotion (Figures 2 and 3B). It may be beneficial, but unknown at this time, whether providing a ramp on the upstream side of the orifice is necessary to allow the lamprey to maintain attachment until out of the high velocity area. For new construction, all orifices should be flush with the floor (no step), and entrance walls should be rounded (8 to 10 cm [~3 to 4 inch] radii). Chamfered corners have also been used but not specifically evaluated and are thus less preferred than rounded corners.

For overflow weirs, rounding the weir and placing the overflow section against the side wall would allow lamprey to maintain continuous attachment (Figure 1). Additionally, special inserts could be put in the guide slots to allow lamprey to use burst and attach locomotion (Figure 6).

5.11.2 Serpentine Weirs

Serpentine weirs, though uncommon and seldom encountered, can be one of the more difficult structural features for lamprey to negotiate and ultimately pass, and these weirs have been associated with high rates of failed passage. Of those lamprey that fail to pass in the serpentine weir sections at Bonneville Dam, few re-attempted passage (Keefer et al. 2012). Serpentine weirs are characterized by square (90°) corners, grated floor sections, and squared vertical slots

that are recessed into fishway walls. Thus, there is high velocity with turbulence, and these conditions are persist over relatively longer distances (up to 0.8 m or 2.5 feet) than the conditions at more traditional vertical slot weirs or orifices. The hydraulic conditions at serpentine weirs has been hypothesized to be beyond the energetic capacity and motivation of some lamprey to continually use burst and attach locomotion at each pool (Keefer et al. 2012, Kirk et al. 2015).

RECOMMENDATIONS: In new construction, avoid serpentine weirs (Figure 4); preferentially use vertical slot (Figure 3A) or a pool and weir type ladder (Figures 1 and 2). Consistent with other recommendations above, these fishways should limit floor diffuser grating; round or chamfer corners in areas with high velocities; and vertical slots should extend to the floor or be ramped (no steps or sill blocks). For existing fishways, possibly provide alternative routes (such as lamprey passage structures/ramps) to bypass serpentine weirs, as was done at the Bonneville Bradford Island and Washington-shore fishways (Moser et al. 2006, 2011).

5.11.3 Differential Between Pools

Differential in elevation between fishway pools for adult salmon and steelhead is typically 0.31 m (1.0 feet; creating 2.1 - 2.4 m/sec [7.0 - 8.0 fps]). For lamprey and smaller resident and migratory fishes, fishways can be constructed with 15 cm (6 inches) differentials (drop), which reduces head between pools and velocities in the orifices. While reducing the differential between pools helps address passage of a wider range of fish species, a larger “footprint”, (additional cost and space) is often necessary to construct a 15 cm (6 inch) drop between each pool. In existing fishways with 0.3 m (1.0 foot) differentials, operational changes at night may be used to improve lamprey passage by reducing head, which reduces overall velocities and energetic requirements for lamprey to pass through the fishway. Several studies have demonstrated that reducing head at the entrances has somewhat improved entrance efficiency (e.g., Daigle et al. 2005; Johnson et al. 2012). In situations where operational changes at existing fishways cannot be accommodated, passage for lamprey may be better addressed with lamprey-specific ramps (lamprey passage structures; see Zobott et al. 2015), provided the ramps can be sited in areas where lamprey are known to congregate.

5.11.4 Bollards

Some experimentation has been done using bollards along a fishway floor to reduce local velocity and thereby provide improved passage for lamprey. In an experimental fishway study, Daigle et al. (2005) placed artificial rocks (10.2 cm wide × 10.2 cm high [4 × 4 inches]), in rows spaced 0.4 m (1.2 feet) apart and staggered so there was 0.7 m (2.3 feet) in between a rock and the rock immediately downstream. These rocks created velocity refuges where lamprey could rest, and improved passage times. Wooden bollards of the same dimensions (10.2 cm wide × 10.2 cm high (4 × 4 inches)) were also tested, and it was found that narrowly spaced bollards (same pattern as above, but only 20 cm [7.9 inches] spacing) decreased passage efficiencies under high head conditions (61 cm [2.0 feet]; Daigle et al. 2005; Keefer et al. 2011). However, at lower head conditions, the bollards did not affect lamprey passage regardless of spacing. Adult Pacific Lamprey had difficulty moving in areas with narrowly-spaced bollards due to turbulent currents they created and the constraints they imposed on lamprey swimming movement (Keefer et al. 2011).

RECOMMENDATIONS: If necessary, employ bollards in areas with high head to provide reduced velocities, in rows spaced at least 0.4 m (1.2feet), with staggered placement (Figure 7A). Bollards may not be necessary in areas where head differentials, and therefore velocities, can be reduced sufficiently.

5.12 Counting Stations and Associated Features

5.12.1 Counting Windows

Initial studies suggested that counting stations may create passage problems for adult Pacific Lamprey (Moser et al. 2002b); however, more recent studies found that lamprey were able to pass the counting window at Bonneville, but were not passing due to unfavorable conditions for lamprey passage in the serpentine weir sections immediately upstream of the counting window (Clabough et al. 2012; Keefer et al. 2010). Nearly all lamprey were able to pass counting windows where the target water velocity is ~ 0.5 m/sec (1.6 fps) in the water column (Clabough et al. 2009), which is well below the sustained swimming speed of Pacific Lamprey (Table 1).

Counting windows designed for salmon may be inadequate for quantifying lamprey (Clabough et al. 2012) as lamprey can pass below the viewing area where the window does not extend all the way to the floor. They may also be able to pass through overly-wide picket leads and avoid the counting window area entirely. Though not a design consideration, Clabough et al. (2012) found that daytime counts greatly underestimated adult Pacific Lamprey passage at counting stations and suggests that efforts to estimate lamprey run size from daytime counts (past or future) should be made with caution or not at all because among year variability in the day:night ratio is very high. Efforts by the Grant County P.U.D. to improve the reliability of lamprey counts are provided in Case Study for Priest Rapids and Wanapum Dam Fishways.

RECOMMENDATIONS: To correct these issues above and improve the accuracy of lamprey counts at these windows, Clabough et al. (2012) made the following recommendations:

- Counting windows should extend all the way to the floor of the passage route, so there are no blind spots at the floor where many lamprey pass undetected, and fish are easily viewed.
- Counting stations should be located near fishway exits and upstream from significant passage challenges to reduce milling behaviors, fallback and repeated attempts — all of which complicate visual counts.
- Infrared light sources should be added improve night counting when most lamprey migrate (see also Section 6.12.2 Lighting).
- To eliminate lamprey avoiding the counting window, spacing of picket leads (or perforated plates or grating) should have open spaces no greater than 1.9 cm (or 0.7 inches). In some cases or regions, this spacing should be further reduced (see Section 6.10.3 Picket Leads).
- Picket Leads for crowders (constrictions in the fishway to force fish to swim near the counting window) may also need to be further reduced beyond 1.9 cm (0.7 inches), as lamprey tend to seek out these areas behind the crowders. These areas are often routes without passage.

5.12.2 Lighting

Artificial lights are present at various locations throughout a fishway, and often needed to see and count fish at counting windows, or necessary security and safety reasons. Changes in illumination levels can occur anywhere within a fishway where the fishway transitions from uncovered to covered areas or lighting is needed for human safety. Daigle et al. (2005) found that lamprey were most active under infrared lighting compared with other types of lights. Because of their nocturnal nature and negative phototaxis, Moser and Mesa (2009) suggested lamprey could be obstructed by very bright or abruptly changing light conditions. The tests to date have not been comprehensive in terms of light spectra or intensity; thus, effects of any lighting are a reasonable potential concern for passage. However, 1 – 3 lux lights were not documented as a problem for lamprey migration (Daigle et al. 2005).

RECOMMENDATIONS: When artificial lighting is necessary, use lights < 3 lux or, preferably, infrared lighting. Also, avoid or eliminate areas/structure that will create sudden changes in fishway light conditions. If lighting must be present in areas for human safety, use curtains or similar material to darken the fishway. Similarly, a refuge box could be used to provide a darkened passageway in areas where artificial lights are necessary, or as a shelter during the day.

5.12.3 Picket Leads

Picket leads are physical barriers used to prevent fish from entering unsafe or non-passage areas within a fishway, or to narrow the passageway at a counting window to force fish to swim near the window. Picket spacing that was intended to exclude adult salmon may allow smaller fish, including adult lamprey, to pass through the open spaces and into areas that were potentially harmful or can cause passage delays. Lamprey have been documented to seek out these areas behind crowdors when picket lead spacing is too wide.

In the lower Columbia River (Bonneville and John Day dams), Moser et al. (2008) found that a gap of 1.9 cm (0.7 inches) or less was necessary to block passage of Pacific Lamprey. Pacific Lamprey were able to compress their body to pass through small gaps, as little as 60% of their body width. The girth of the brachial basket was hypothesized to be the limiting part of their anatomy, as length, weight and girth of body was not a good indication. This structure is less flexible than other parts of the body and appears to remain constant in size, even as body mass shrinks over time.

RECOMMENDATIONS: Picket lead gaps should be ≤ 1.9 cm (0.7 inches) for new migrants entering the lower Columbia River Basin. A reduced gap size may be required for other areas, such as the interior Columbia Basin, because adult lamprey shrink over time. Pacific Lamprey in the upper Columbia Basin, and perhaps other lamprey in different drainages outside of the Columbia River, may be smaller; thus, site-specific sizes of adult lamprey should be considered and picket spacing should be reduced as needed. Using perforated plate, grating, or bar rack instead of pickets — where hydraulically feasible — may also further limit the potential for lamprey to pass into undesirable areas. Care should be taken to ensure adequate porosity when using perforated plate or bar rack material.

5.13 Cul de Sacs and Dead Ends

Be it boulders, cobble, trees, or other structures in rivers (e.g., see Robinson and Bayer 2005; Clemens et al. 2010, 2012), log structures in crib dams (e.g., Lampman 2011) or structures within fishways (Keefer et al. 2012), Pacific Lamprey seek out structure to hold shelter under when they are not actively migrating. Adult lamprey have been found in several fishway features that do not have upstream outlets, particularly those with associated attractive flows (Keefer et al. 2012). For example, lamprey may be attracted to seepages or leaks in infrastructure that may lead them to dead ends, which can contribute to passage delays or failures, though some of these areas were found to provide resting areas for adult lamprey (Keefer et al. 2012).

At Bonneville Dam, adult Pacific Lamprey were passing through picket leads and accumulating in an area with no passage adjacent to the counting window (Moser et al. 2006). Lamprey were also having difficulty passing the serpentine weir section above the counting window. Instead of modifying the picket leads to prevent lamprey from entering the area, lamprey passage structures (LPS, which are lamprey-specific ramps; see Zobott et al. 2015 for design details) and a counting mechanism were installed that allowed lamprey to bypass the counting station and serpentine weir section, and enter the forebay above the dam (Moser et al. 2006, 2011). Subsequently, picket leads were raised off the floor slightly to allow lamprey (but not salmon) easier access to the area (Keefer et al. 2012)

RECOMMENDATIONS: Examine cul de sacs and dead ends for lamprey aggregations. If lamprey are accumulating in such areas, exclude lamprey from these areas, or provide means for egress, such as lamprey passage ramps. For example, remove the attractiveness of infeasible migration routes to lamprey that are likely to delay their passage. Isolate the areas either via picket leads or grating, and permanently remove access to lamprey (dewater the area). In some circumstances, it may be possible to take advantage of and modify the situation, such as adding lamprey passage ramps where lamprey congregate in dead-end areas, as described in the case studies below) to provide passage. For example, such additions have successfully been used at Willamette Falls and Bonneville Dam (Moser et al 2006 and Case Study at Willamette Falls).

5.14 Salmon Fishway Exits

Fishway exits can pose challenges to lamprey passage similar to those found at the entrance: specifically, shear flows, sharp corners and bulkhead slots that may be in areas with high velocities. See recommendations in Section 6.2 – 6.4 for recommendations to address those problems.

Immediately after exiting a fishway, fish should not encounter sudden or high velocity downstream currents that could potentially carry them back downstream over the structure they just passed (such as spillways or turbine intakes). While most salmon fishways follow this guideline, lamprey could be swept downstream in conditions where adult salmon would not.

RECOMMENDATIONS: For existing structures, exits may need to be ramped on the upstream side to allow lamprey to move to lower velocity areas and away from areas where spillway or

turbine currents or shearing flows could sweep them back downstream and back over the structure they just passed. To reduce lamprey fallback, new construction should avoid high velocity exit sites, or ensure that adequate ramps or other transitions to low velocity areas allow lamprey to orient and swim upstream easily after exiting the fishway.

TABLE 3. Summary table of guidelines, recommendations, and key uncertainties for passage of adult Pacific Lamprey in fishways, with associated literature and case studies.

Ladder Component/ Problem (in italics)	Guideline/Recommendation	Key Uncertainties	Relevant Literature/Case Studies
ENTRANCES			
Attraction flows/ Entrance openings <i>High velocities/ shear velocities with limited attachment surfaces.</i>	<p>Multiple fixes (implemented individually or in combination) may be needed and include:</p> <ul style="list-style-type: none"> ● Reduced velocities via operational changes <ul style="list-style-type: none"> ○ Reduce auxiliary water supply at the entrance so that water velocity is ≤ 1.0 m/sec (3.3 fps), to maintain sufficient attraction volume while allowing lamprey to swim through the entrance. ○ May be able to only reduce flows at night to avoid negative effects on salmonid passage, which primarily occurs during the day. ● Physical modifications to the entrance in areas of increasing velocities (≥ 1.0 m/sec (~3.3 fps)), and or increasing turbulence regardless of velocities: <ul style="list-style-type: none"> ○ Provide continuous planar areas for attachment (continuous floor, ramp, or wall). ○ Provide rounded (8 to 10 cm [~ 3 to 4 inch] radii). Chamfered corners have also been used but not specifically evaluated and are thus less preferred. ○ Locate orifices (or slots) along the floor without a step/sill (Figure 2). ○ Locating the orifices in the corner of a weir will provide a continuous attachment surface along both the floor and the wall, which provides more attachment opportunities for lamprey (Figure 2). ○ If a step is present along the floor, add a 3:1 ramp on the downstream side. ○ Install bollards along the floor to reduce velocities (see 	<p>Site specific information should determine which fix or suite of fixes is needed.</p> <p>The 3:1 ratio for ramps and 8 to 10 cm (~ 3 to 4 inch) radii for rounded edges represents best professional judgment. No quantitative studies on this available.</p> <p>It may be beneficial, but unknown at this time, whether providing a ramp on the upstream side of the orifice is necessary to allow the lamprey to maintain attachment until out of the high velocity area.</p>	<p>Clabough et al. 2015; Daigle et al. 2005; Johnson et al. 2012; Keefer et al. 2011, 2012; Kirk et al. 2015, <i>In press</i>; Moser & Mesa 2009</p> <p>Case Studies: Walterville Adult Fish Return channel; River Mill Fishway</p>

“Bollards” below) - experimentally done at Bonneville and John Dam Dams.

- Use of a variable width entrance weir to produce sufficient attraction flows high in the water column while reducing flow velocity near the floor at Bonneville and John Day dams (Clabough et al. 2015).
- Also see guidance (below) on sharp angles/corners, bulkhead slots/stop logs, and diffuser gratings, all of which can be associated with entrances.

PHYSICAL MODIFICATIONS

<p>Sharp Angles/ Corners <i>lack of attachment surfaces</i></p>	<p>Avoid sharp angles or corners (90°) in areas of velocities above 1.0 m/sec (3.3 fps), which hinder lamprey from using burst and attach locomotion. Rounding (> 8 to 10 cm (~3 to 4 inch) radii) the orifice walls or entrance walls is advised on both the up- and downstream sides of each wall (Figure 2). Rounding the orifice walls at an existing fishway can either be accomplished via rounding the wall, or installing inserts around the wall (see Figure 1). Chamfered corners have also been used but have not specifically been evaluated and are thus less preferred.</p>	<p>The > 8 to 10 cm (~3 to 4 inch) radii for rounded edges represents best professional judgment and not directly supported by specific research.</p>	<p>Keefer et al. 2010 Case Studies: EWEB Walterville Adult Fish Return channel; River Mill Fishway</p>
<p>Bulkhead slots/ stoplog slots <i>lack of attachment surfaces</i></p>	<p>When bulkhead slots are present and velocity ≥ 1.0 m/s (3.3 fps), eliminate the slot or gap when the gates/stop logs are not in place, to provide a continuous planar surface for attachment (Figure 6). Design inserts to create a smooth continuous surface with no gaps or abrupt surface changes (bumps) in the transition between the fishway wall and the insert.</p> <p>For new construction, the gate bulkhead slot system can be designed so there are no slots along floor or lower walls (0.3 m or 1.0 foot) of entrance.</p>		<p>Keefer et al. 2010 Case Studies: Walterville Adult Fish Return channel; Willamette Falls –Ladder Entrance 1</p>

<p>Diffuser Grating <i>lack of attachment surfaces; potentially confusing hydrologic cues</i></p>	<p>All diffuser grating should be sized appropriately to prevent lamprey from entering unsafe areas or dead ends. For the lower Columbia River, ≤ 1.9 cm (0.7 inches) open space between bars is recommended. Other areas may require smaller openings to prevent entry (see Pickett discussion).</p> <ul style="list-style-type: none"> ● Wall diffusers located in high velocity areas (≥ 1.0 m/s, 3.3 fps) should be elevated off the floor by at least 0.3 m (1.0 ft). ● Floor diffusers in high velocity areas: <ul style="list-style-type: none"> ○ Should be located at least 1 m (3.3 ft) above and below (e.g., horizontally) weir orifices (Figures 7A and 7B). ○ To provide a continuous attachment surface where existing floor diffuser grating is necessary, a flat metal plate (minimum width of 0.31 m (1.0 ft)) can be used to span diffuser floors and provide attachment areas (Figures 7A and 7B). ○ Omitting diffuser gratings from the floors and lower walls of a fishway minimizes the stranding potential when dewatering for maintenance, inspections, etc. 	<p>The height at which wall diffusers are recommended (0.3 m or 12 inches above the floor) represents best professional judgment and not directly supported by specific research. Open spacing requirement was based on lamprey sizes at Bonneville Dam in the lower Columbia River. Smaller spacing may be necessary in other areas; such adjustments should be based on site-specific information on adult lamprey size.</p>	<p>Moser et al. 2008, Keefer et al. 2010, Keefer et al. 2011, 2012</p>
<p>TRANSITIONAL AREAS</p>			
<p>Collection Channels <i>confusing hydrologic cues</i></p>	<p>Assuming the problem with collection channels is associated with hydraulic cues and attraction, new construction should incorporate features to better attain uniform hydraulic flow for lamprey along the floor, while still providing opportunities for resting.</p> <p>The use of refuge boxes in areas where lamprey have higher rates of fallback may prove useful (see section 6.5 Resting Areas, Figure 8).</p> <p>For existing or new construction, alternative routes that bypass the collection channel (or portions of it) using lamprey passage structures (ramps) could also be used if conditions and behavior suggested ramps might be successful.</p>	<p>The passage problem in these channels and appropriate solutions are site specific and not well understood at this time.</p> <p>Unknown how frequent refuge/ rest areas should be available, but assume more areas are needed more frequently in longer ladders.</p>	<p>Keefer et al. 2012, 2013a; Kirk et al. 2015; Corbett et al. 2013, 2014, 2015</p> <p>Case Study: Bonneville Refuge Box</p>

<p>Transition Pools/ Junction Pools <i>confusing hydrologic cues</i></p>	<p>New construction should ensure there are sufficient hydraulic cues for fish to continue upstream, and incorporate features to better maintain uniform hydraulic flow for lamprey along the floor in these pools, while maintaining sufficient resting areas. Placement of refuge boxes as could provide such resting areas (see Section 6.5 Resting areas, Figure 8).</p> <p>For existing or new construction, alternative routes that bypass these pools using lamprey passage structures (ramps) could also be used if conditions and behavior suggested ramps might be successful.</p>	<p>The passage problem in these areas and appropriate solutions are site specific and not well understood.</p>	<p>Clabough et al. 2015; Keefer et al. 2012, 2013a; Kirk et al. 2015</p> <p>Case Studies: Bonneville Refuge Box, Three Mile Falls Dam LPS, Prosser Dam Wetted Wall LPS</p>
<p>WEIR SECTIONS</p>			
<p>Submerged Orifices <i>Limited attachment surfaces</i></p>	<p>Provide continuous planar floor surfaces for lamprey attachment until outside of the high velocity (≥ 1.0 m (3.3 feet) area of the orifice upstream and downstream of an orifice or weir)</p> <ul style="list-style-type: none"> ● Make orifices flush with the floor (no steps) and/or flush to the outside fishway wall (Figure 2). If at least one continuous planar surface is provided, (i.e., the floors), then rounded corners may not be needed at remaining edges of the orifice. ● If steps are present, ramps can be added on the downstream side of the orifice to allow for burst and attach locomotion (Figures 2, 3A and 3B). ● For new construction, all orifices should be flush with the floor (no step), and entrance walls should be rounded (8 to 10 cm (~3 to 4 inch) radii). Chamfered corners have also been used but not specifically evaluated and are thus less preferred. 	<p>It may be beneficial, but unknown at this time, whether providing a ramp on the upstream side of the orifice is necessary to allow the lamprey to maintain attachment until out of the high velocity area.</p>	<p>Keefer et al. 2012, 2013a; Moser et al 2002b</p> <p>Case Study: Priests Rapids/Wanapum Dam Fishways; River Mill Fishway</p>
<p>Overflow Weirs <i>High velocities/ shear velocities with limited attachment surfaces</i></p>	<p>For overflow weirs, round the weir and place the overflow section against the side wall to allow lamprey to maintain continuous attachment (Figure 1). Special inserts may be put in the guide slots (if present) to eliminate the gap and allow lamprey to use burst and attach locomotion (Figure 6).</p>		<p>Keefer 2013a</p>

<p>Vertical Slot <i>Limited attachment surfaces</i></p>	<p>No specific recommendations, except to follow relevant recommendations provided in elsewhere in this document.</p> <p>Wetted wall LPS have been installed at Prosser Dam to improve upstream passage success and allow lamprey to bypass portions of the salmonid fishway.</p>	<p>Case Study: Prosser Dam Wetted Wall LPS</p>	
<p>Serpentine Weir <i>High velocities/ shear velocities with limited attachment surfaces;</i></p>	<p>In new construction, avoid serpentine weirs (Figure 4); preferentially use vertical slot (Figure 3A) or a pool and weir type ladder (Figures 1 and 2) with the appropriate modifications (rounded corners, sufficient areas of attachment where needed, etc.).</p> <p>For existing fishways, provide alternative routes (such as lamprey passage structures/ramps) to bypass serpentine weirs, as was done at the Bonneville Bradford Island and Washington-shore fishways.</p>	<p>Clabough et al. 2009; Keefer et al. 2010, 2012, 2014; Kirk et al. 2015; Moser et al. 2006, 2011</p>	
<p>Pool and Chute <i>Limited attachment surfaces</i></p>	<p>No specific recommendations, except to follow relevant recommendations provided in elsewhere in this document.</p>		
<p>Resting Areas <i>Insufficient resting/ refuge areas</i></p>	<p>Provide resting opportunities at regular intervals throughout a fishway, particularly where fishway length, elevation gain or ascent distance is substantial, or in areas where lamprey have been shown to fall back out of the fishway. Each resting area should provide areas of relatively low velocity (e.g., 0.9 m/sec or less) and darkness, with natural substrate, such as the refuge boxes (Figure 8).</p>	<p>Unknown how frequent refuge/ rest areas should be available, but assume more areas are needed more frequently in longer ladders.</p>	<p>Daigle et al. 2005, Keefer et al. 2011, Corbett et al. 2013, 2014, 2015 Case Study: Refuge Boxes at Bonneville</p>
<p>Cul de sacs/ Dead ends <i>Unnecessary energy expenditure</i></p>	<p>Exclude lamprey from these areas, or provide means for egress (i.e., lamprey ramps). Isolate the areas either via picket leads or grating, or permanently remove access to lamprey (dewater the area).</p>	<p>Keefer et al. 2012 Moser et al. 2006</p>	<p>Case Studies: Willamette Falls; Three Mile Dam; Prosser Dam</p>

Counting Stations		
Counting Windows	<ul style="list-style-type: none"> Counting windows should extend all the way to the floor of the passage route, so there are no blind spots at the floor where lamprey may pass undetected, so that fish are easily viewed. Counting stations should be located near fishway exits and upstream from significant passage challenges to reduce milling behaviors, fallbacks and repeated attempts- all of which complicate visual counts. Infrared light sources should be used to improve night counting and reduce behavioral effects when most lamprey migrate. Use appropriate spacing for any picket lead or other exclusion grating to ensure lamprey must pass at the counting window. 	<p>Clabough et al. 2009, 2012</p> <p>Case Study: Priests Rapids/Wanapum Dam Fishways)</p>
Lighting	<p>When artificial lighting is necessary, use lights < 3 lux or, preferably, infrared lighting. Also, avoid or eliminate areas/structure that will create sudden changes in fishway light conditions.</p>	<p>Daigle et al. 2005, Moser et al. 2002</p>
Picket leads	<p>Open space between picket leads (or perforated plates, grating, etc.) should be no greater than 1.9 cm (or 0.75 inches), and in some cases or regions, this spacing should be further reduced. Using perforated plate, grating, or bar rack instead of pickets — where hydraulically feasible — may also further limit the potential for lamprey to pass into undesirable areas. Ensure adequate porosity when using perforated plate or bar rack material.</p>	<p>Open spacing requirement was based on lamprey sizes at Bonneville Dam in the lower Columbia. Upstream areas or other basins may require reduced spacing based on site-specific information on adult lamprey size.</p> <p>Moser et al. 2008</p> <p>Case Study: Priests Rapids/Wanapum Dam Fishways)</p>
EXITS		
Exit location	<p>For existing structures, exits may need to be ramped on the upstream side to allow lamprey to gradually move to lower velocity areas and away from areas where spillway or turbine currents or shearing flows could sweep lamprey back downstream and over the structure they just passed.</p>	

New construction should locate exits away from hazardous areas, or ensure adequate ramps and transition areas to low velocity areas to avoid fallback.

ATTACHMENT SURFACES

Attachment surfaces	<p>Ensure a smooth continuous surface (no gaps or abrupt surface changes) at least 0.3m (1 foot) wide for the entire length of the area with velocities in excess of 1.0 m/sec (~3.3 fps). Surface irregularities should not exceed 2 mm (0.08 inch). For modifications that require inserts (bulkhead slots, rounding sharp corners, ramps, etc.), flat plate aluminum may be used to provide a smooth continuous surface for lamprey passage. Aging the structure after construction may be beneficial. To create floor ramps for lamprey to pass orifices with steps or sill blocks, concrete could be placed, formed, and smoothed. Surfaces such as smoothly painted surfaces, plastics, glass, concrete, rubber mats, etc., may also provide adequate attachment surfaces.</p>	<p>Surface must allow the oral disk of the lamprey to create a reliable seal.</p> <p>For Sea Lamprey, surfaces with narrowly spaced grooves of 1 mm (0.04 inch) width and 3 mm (0.12 inch) depth prevented attachment. No studies specific to Pacific Lamprey have been conducted.</p>	<p>Adams and Reinhardt 2008</p> <p>Case Study: Priests Rapids/Wanapum Dam Fishways); Willamette Falls</p>
----------------------------	--	--	--

OTHER

Bollards	<p>If necessary, employ bollards in areas with high head to provide reduced velocities, in rows spaced at least 0.35 m (1.15 feet), with staggered placement (Figure 7A). Bollards may not be necessary in areas where velocities can be reduced to ≤ 1.0 m/sec (3.3 fps).</p>	<p>Use of bollards and benefits not fully understood.</p>	<p>Clabough et al. 2015, Daigle et al. 2005, Keefer et al. 2011</p>
Temperature	<p>Ensure fishway temperatures are below 20° C when adult lamprey are actively migrating. Where temperatures exceed 20° C, inputs of cooler water from an upstream source (if available) could be added to the fishway to reduce the water temperatures. Use of shade cloth or similar material over the fishway could also lessen solar radiation effects and reduce warming.</p>	<p>Temperature has an effect on lamprey passage in fishways, but these effects are poorly understood.</p>	<p>Clemens et al. 2009, 2012, 2016, 2017; Keefer et al. (2013a)</p>

Predation Issues

Consider the number and size of potential predators on lamprey and incorporate measures to reduce access and opportunities of such predators. Actions may include reducing access of large predators with physical barriers (e.g., Sea Lion Exclusion Devices), use of acoustic deterrents, or hazing. For smaller predators, such as river otter, installing barriers/fencing to limit overland access into the fishway or providing refuge boxes for cover from predation may reduce predator opportunities. Other options include removal of predators by trapping. Installation of ropes, wires, sprinkler systems, or flagging may deter avian predators, such as herons. Providing natural substrate (such as large cobbles) in areas with no cover may also provide refuge from predators.

Kirk et al. 2015,
Madson and Van
der Leeuw 2016,
Tackley et al.
2008

Case Studies:
Refuge Boxes

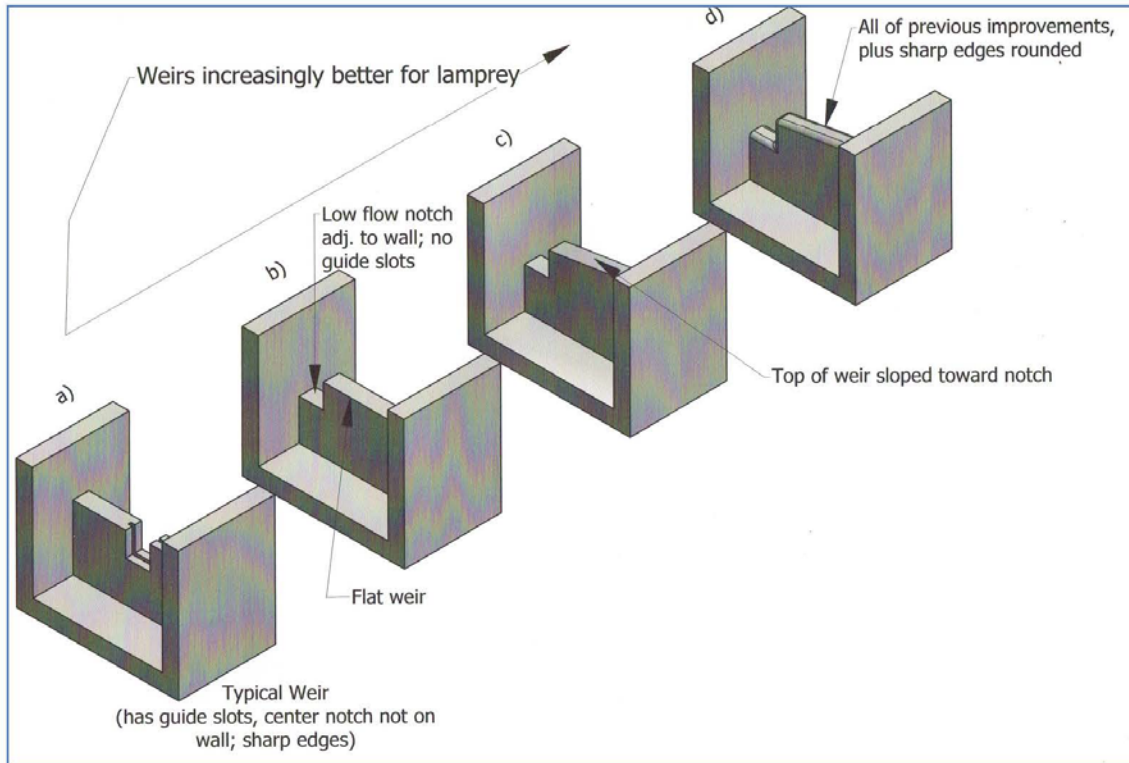

Figure 1. LAMPREY ISSUES WITH OVERFLOW WEIRS AND SUGGESTED IMPROVEMENTS FOR PASSAGE. (a) This type of passage structure is not ideal for lamprey passage because the stoplog guide slots lack a continuous planar surface for lamprey attachment. (b) Overflow weir without stoplog slots, located along the outside wall of a fishway. This configuration is expected to improve lamprey passage because the outside wall provides a continuous planar surface where lamprey should be able to use burst and attach locomotion to pass upstream. (c) This overflow weir improves upon (b) because the tallest part of the wall is gently sloped to provide an area of diminished flow (assuming water does not overtop the entire weir) which can provide improved lamprey passage. (d) This overflow weir improves upon (b) and (c) because the sharp corners have been rounded, thus providing more attachment surfaces for lamprey.

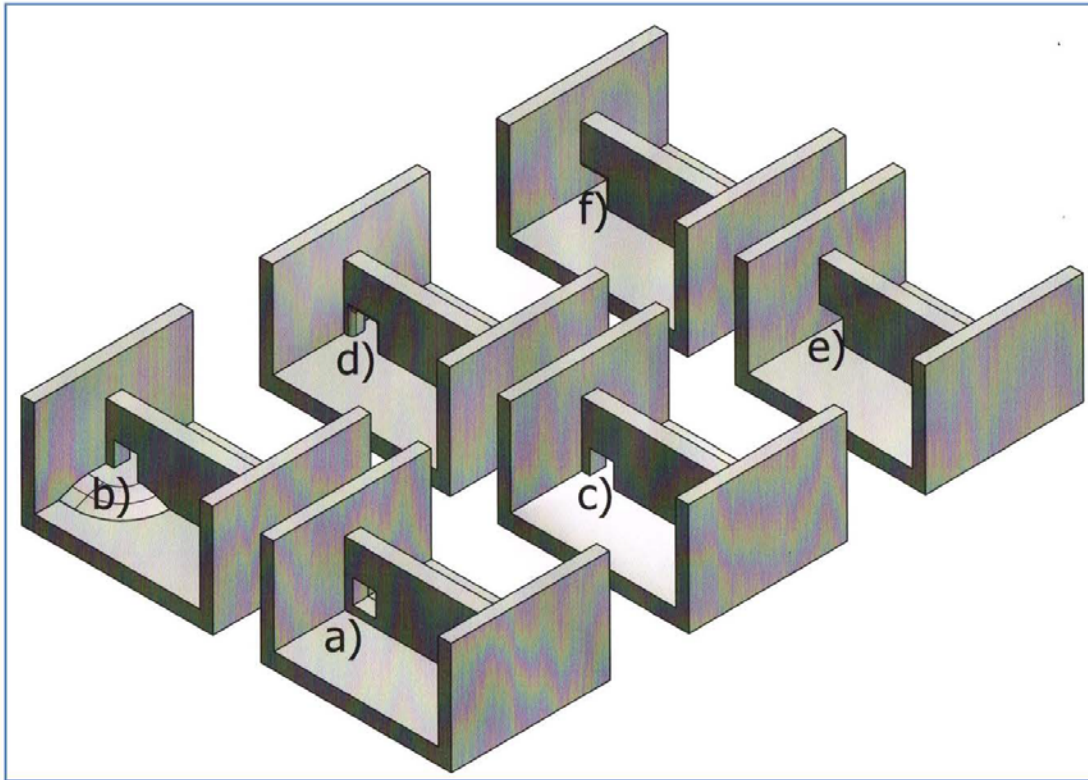

Figure2. LAMPREY ISSUES WITH SUBMERGED ORIFICES AND SUGGESTED IMPROVEMENTS FOR PASSAGE. (a) Typical submerged orifice has a step (perched above the floor), offset from the outer wall. This configuration does not provide a continuous planar surface for lamprey attachment. (b) The addition of a ramp on both the upstream and downstream sides of the step can improve lamprey passage by providing a continuous planar surface. Suggest a 3:1 horizontal: vertical slope. (c) Placing the orifice along the floor of the fishway should eliminate the need for a ramp. (d) The addition of rounded edges (10 cm [\sim 4 inches]) of the orifice walls should provide more opportunities for lamprey attachment. (e) Placing the orifice along the outer wall and along the floor provides two areas with continuous planar areas for lamprey attachment. (f) The addition of rounded edges (10 cm [\sim 4 inches]) on all orifice corners (sides and top) also should provide more opportunities for lamprey attachment.

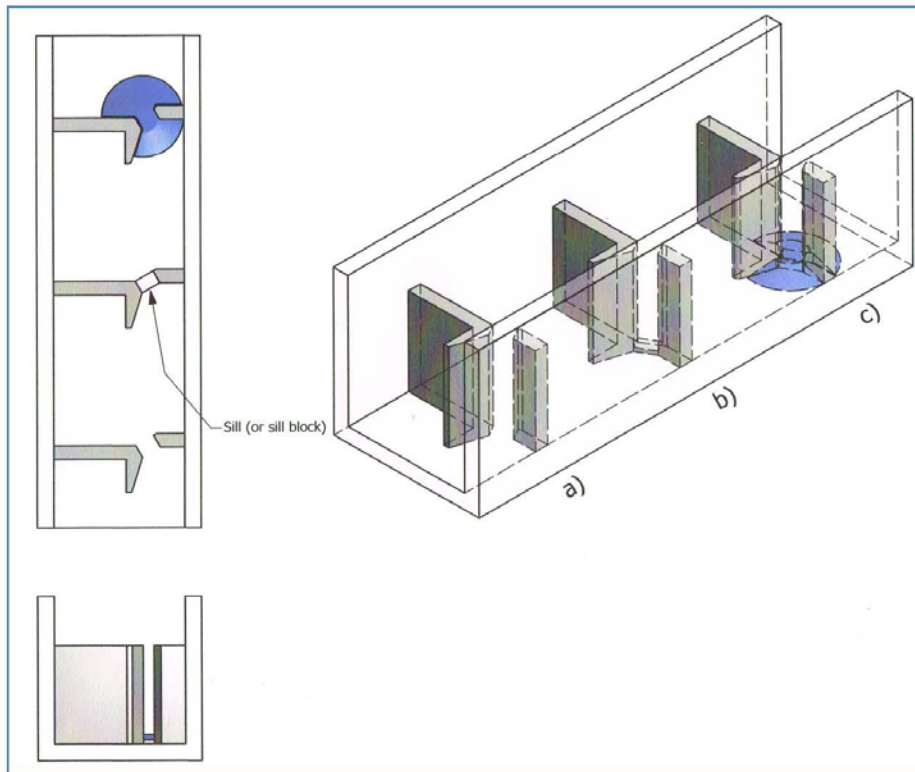

Figure 3A. LAMPREY IMPEDIMENTS AND REMEDIES AT VERTICAL SLOT FISHWAYS. (a) Weir with planar floor in slot that should be amenable for lamprey attachment. (b) Some vertical slot fishways have sills (or sill blocks) as shown in weir (b). Sills and sill blocks are not desirable for lamprey passage because these structures disrupt continuous planar surfaces, making it difficult for lamprey to attach. (c) This weir has a ramp (see Figure 3B) over the sill block that should facilitate continuous attachment – and thus passage – by lamprey. The vertical edges of these slots are also rounded with 10 cm (~4 inch radii) to further facilitate attachment and passage by lamprey (the rounded edges are difficult to discern in this figure).

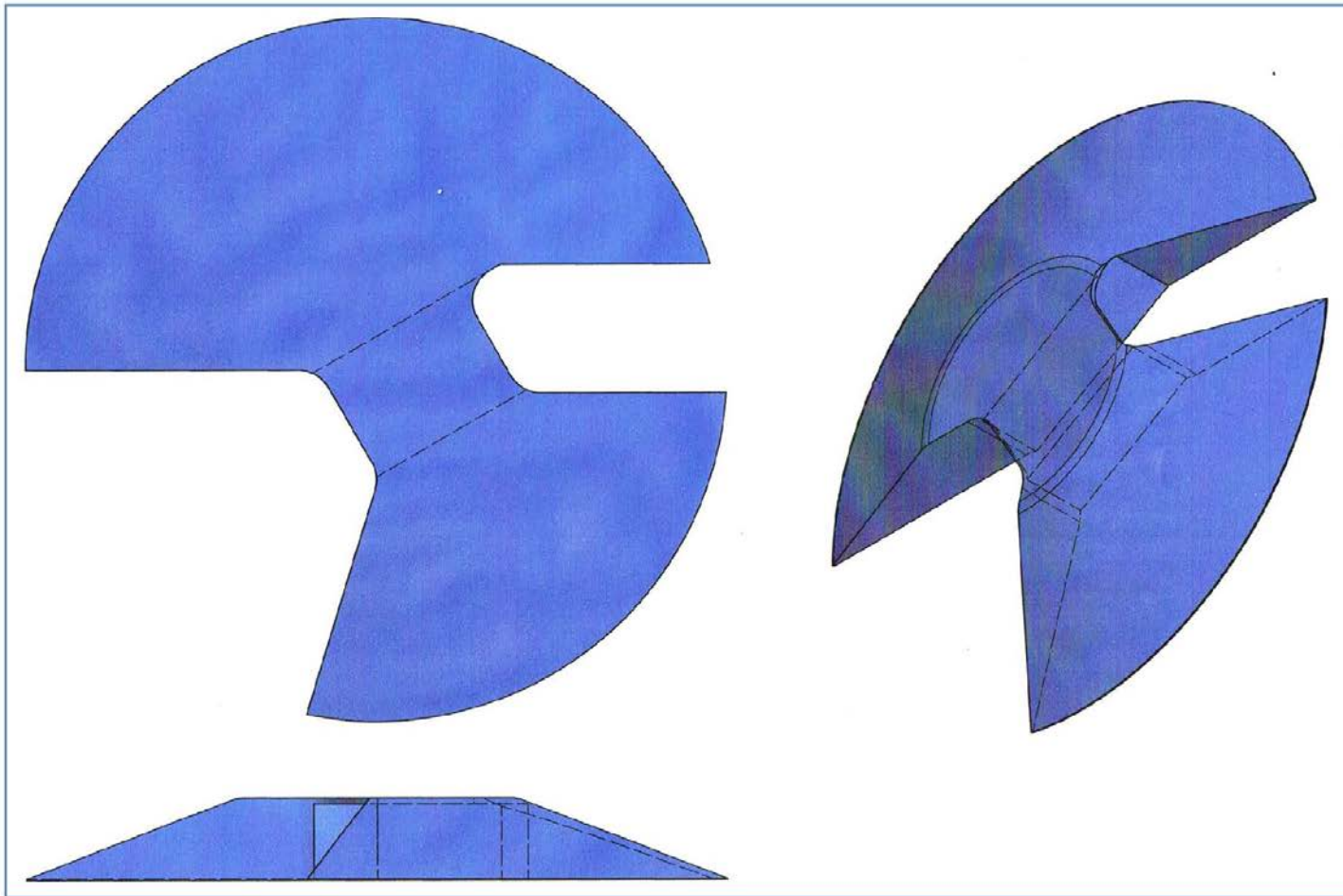

Figure 3B. RAMP FOR SITUATIONS WHERE THERE IS A SILL OR SILL BLOCK. Shown in smaller scale in Figure 3A.

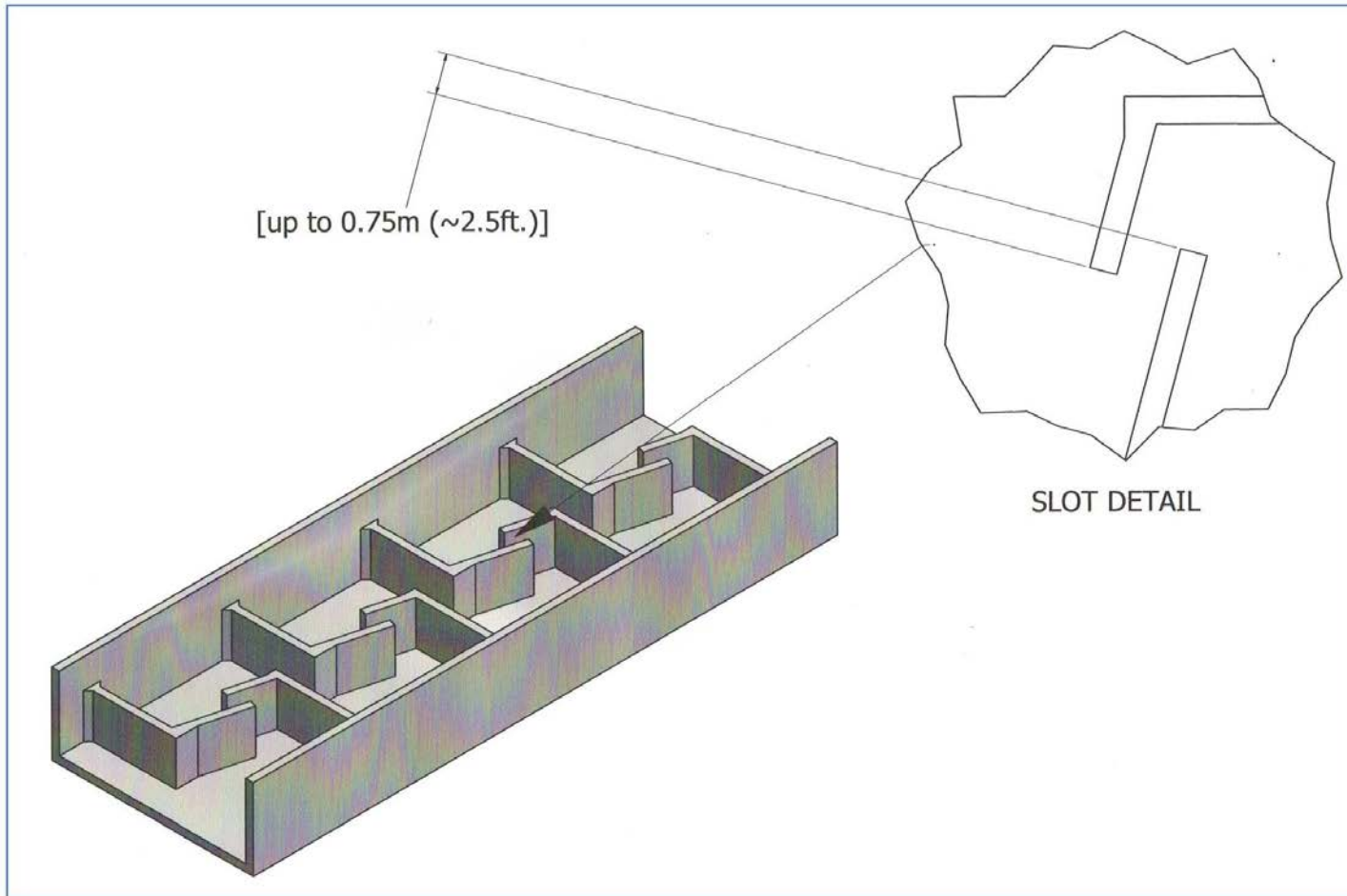

Figure 4. LAMPREY ISSUES AT SERPENTINE WEIRS. Serpentine weirs are thought to be problematic for lamprey passage because the slot configuration creates a longer length (up to 0.75 m [\sim 2.5 ft.]) of higher velocity flows relative to other types of ladders.

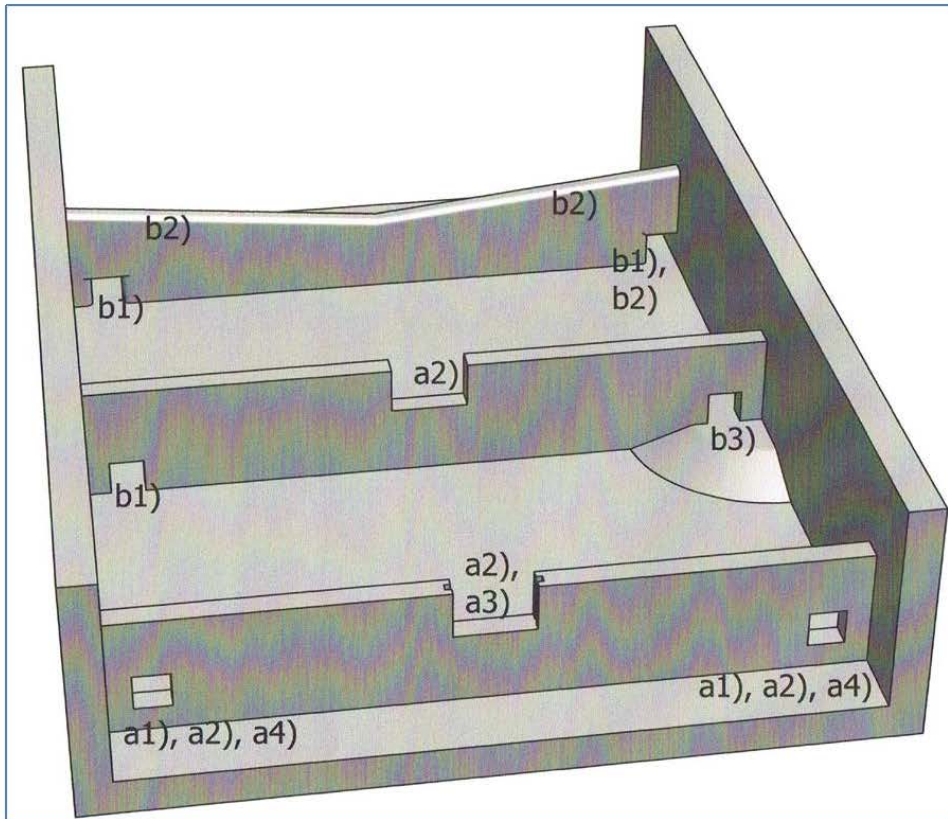

Figure 5. LAMPREY ISSUES VARIOUS FISHWAY FEATURES. (a) Typical fishway features are: (a1) Orifices off the floor and walls (not conducive to lamprey attachment). (a2) Weir edges are sharp (difficult for lamprey to attach). (a3) Notch has sharp-edged stoplog slots (difficult for lamprey to attach). (a4) Orifices are square-edged, set apart from the floor and walls. (b) Weir elements modified to provide for lamprey passage. (b1) Orifices lowered to the floor. (b2) Sharp edges radiused (rounded with 10.2 cm [4 inches] radii). (b3) Ramp built up to perched orifices.

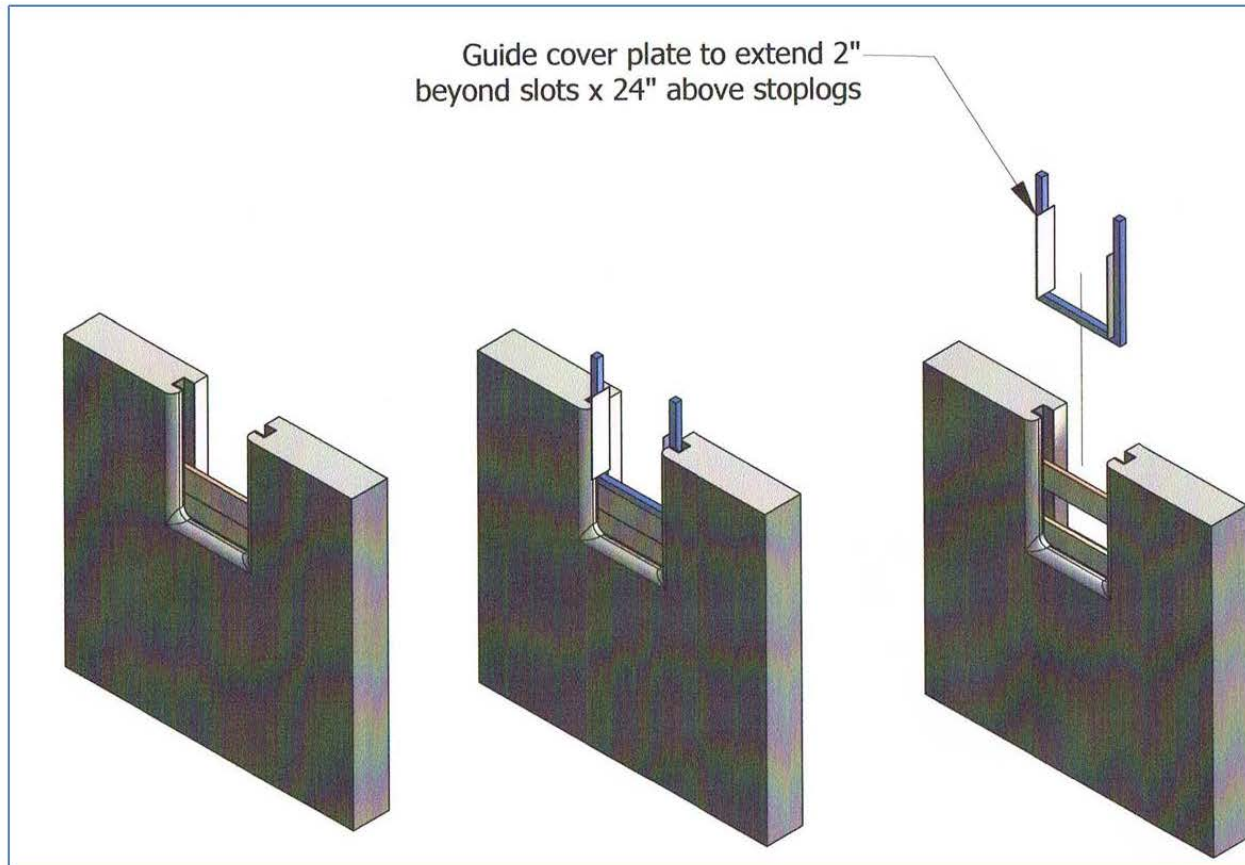

Figure 6. IMPROVED STOPLOG SLOTS (cast-in-place version). (a) Typical weir slots with stoplogs are difficult for lamprey to pass because guide slots prevent utilization of burst and attach locomotion. (b) Weir slot with covers over the guide slots. Slot covers should extend 0.31 m (~12 inches) above the water surface. (c) Exploded view of stoplog slot cover.

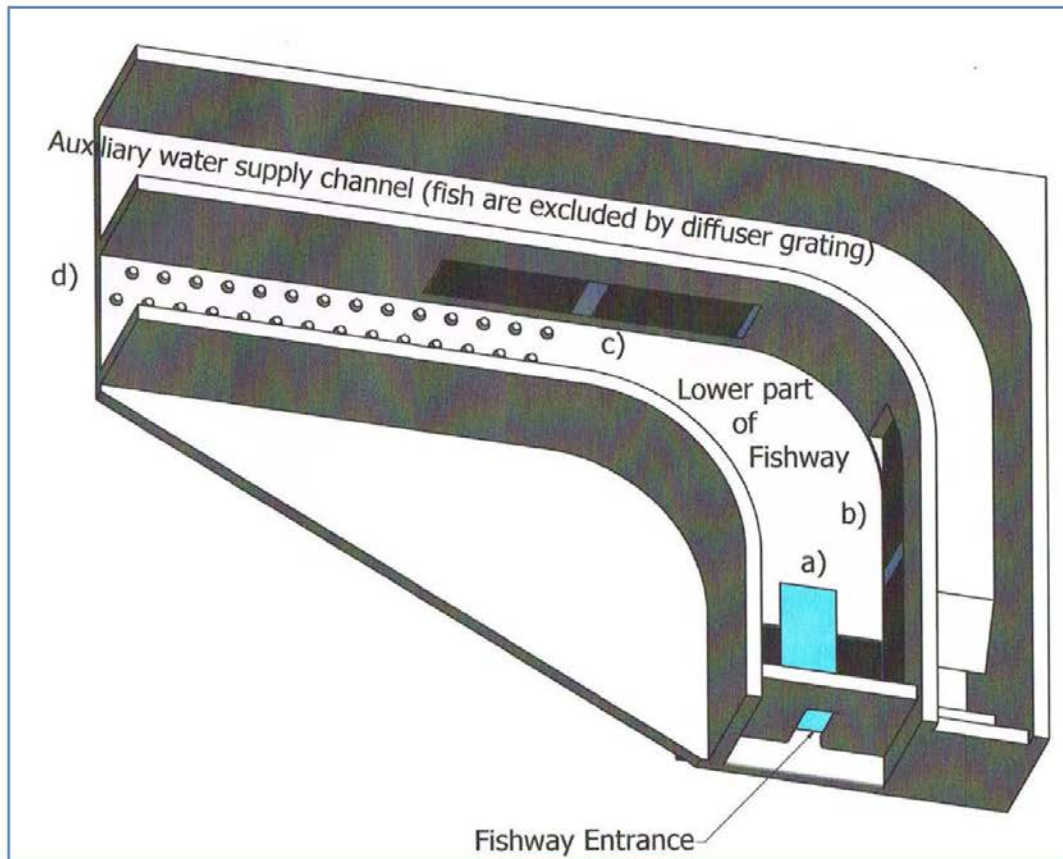

Figure 7A. LAMPREY ISSUES WITH DIFFUSERS. (a) Bottom diffuser immediately upstream of a gate opening. In this case it is preferred to cover the plate with a sheet of metal so that the lamprey will have something to attach to when they pass through the high velocity of the fish entrance. (b) This wall diffuser is near flush with the floor (minimal attachment opportunity for lamprey along the wall). (c) This wall diffuser is raised 0.31 m (~12 inches) above the floor, thus providing some attachment opportunities for lamprey. (d) A bollard array provides small resting areas for lamprey. Bollards may improve lamprey passage in higher velocity areas.

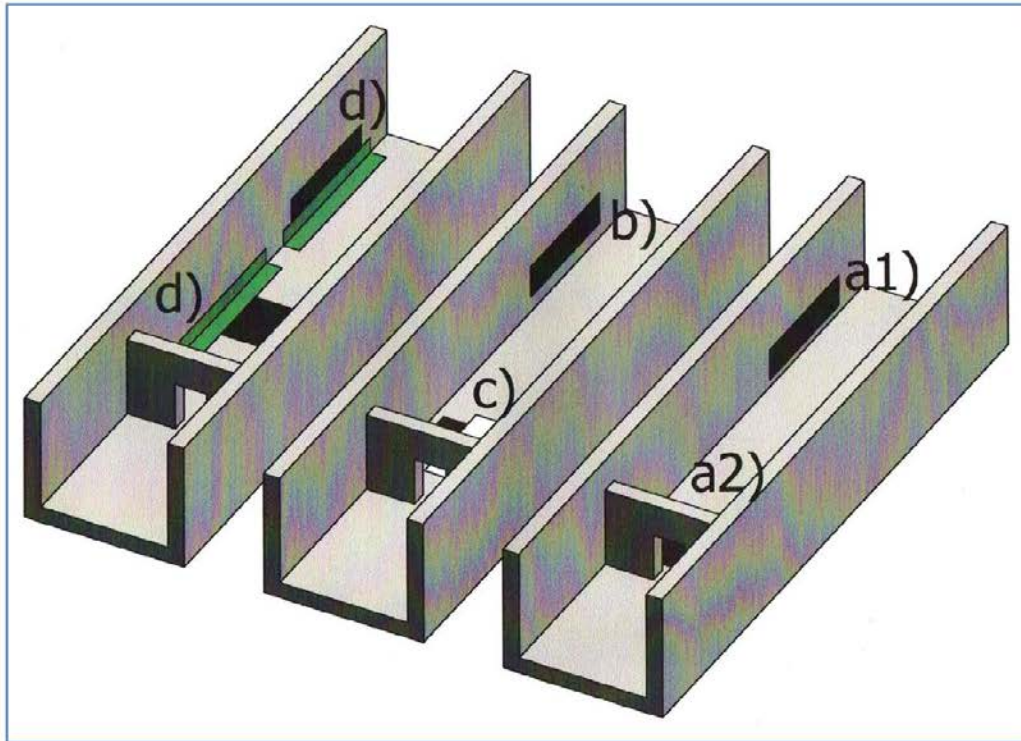

Figure 7B. LAMPREY IMPROVEMENTS AT DIFFUSERS (auxiliary water gratings). (a) Typical situation in fishways with high velocity areas (> 1 m/s [~ 3 fps]), which is a poor situation for lamprey passage. (a1) Wall diffuser < 0.31 m (~ 1 ft.) from the floor interrupts attachment opportunities by lamprey in high velocity areas. (a2) Floor diffuser is immediately adjacent to high velocity area (orifice) where attachment opportunities are needed for lamprey. (b) Improved wall diffuser because it is > 0.31 m (~ 1 ft.) above the floor, thus providing attachment opportunities for lamprey below the diffuser. (c) Place metal sheet over the diffuser when it is < 1 m (~ 3 ft.) away from high velocity orifice area. Note: In this depiction the diffuser is actually > 1 m (~ 3 ft.), but the plate is shown nevertheless to illustrate the idea when the diffuser is closer than shown. (d) In high velocity areas (> 1 m/s [~ 3 fps]) over diffusers, cover the diffuser to 0.31 m (~ 1 ft.) on the floor and wall to provide a place for lamprey to attach.

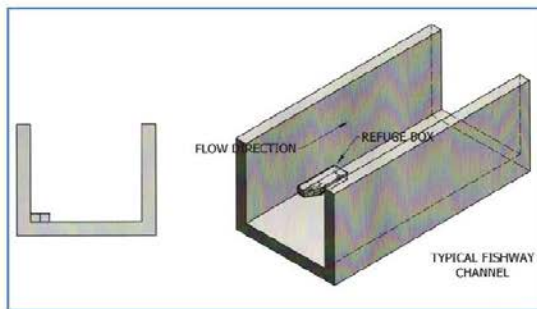
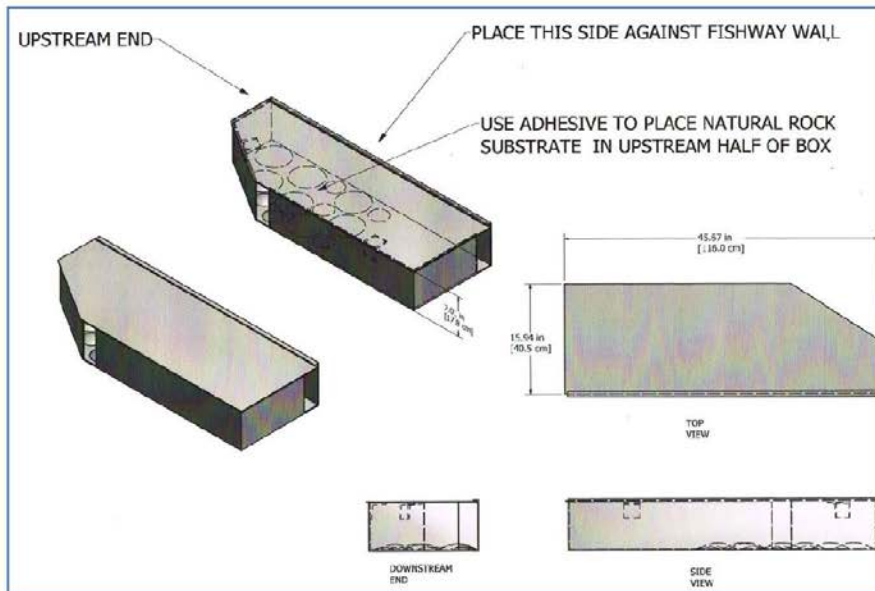

Figure 8. LAMPREY REFUGE BOX (upper) AND TYPICAL PLACEMENT OF REFUGE BOX IN FISHWAY (lower), both as described in Corbett et al. (2013).

6 LITERATURE CITED

- Adams, R.D., and U.G. Reinhardt. 2008. Effects of texture on surface attachment of spawning run sea lampreys *Petromyzon marinus*: a quantitative analysis. *Journal of Fish Biology* 73:1464–1472.
- Agostinho, A.A., L.C. Gomes, D.R. Fernandez, and H.I. Suzuki. 2002. Efficiency of fish ladders for neotropical ichthyofauna. *River Research and Applications* 18:299–306.
- Agostinho, A.A., F.M. Pelicice, A.C. Petry, L.C. Gomes, and H.F. Julio, Jr. 2007. Fish diversity in the upper Parana River basin: habitats, fisheries, management and conservation. *Aquatic Ecosystem Health and Management* 10:174–186.
- Beamish, F.W.H. 1978. Swimming capacity. Pages 101-187 *in*: W. S. Hoar and D. J. Randall, editors. *Fish physiology*, volume 7. Academic Press, New York.
- Bell, M.C. 1991. Fisheries handbook of engineering requirements and biological criteria. U.S. Army Corps of Engineers, North Pacific Division. Fish Passage Development and Evaluation Program. Third edition. p. 6.3
- Clabough, T.S., E.L. Johnson, M.L. Keefer, C.C. Caudill, C.J. Noyes, J. Garnett, L. Layng, T. Dick, M.S. Jepson, K.E. Frick, S.C. Corbett, and B.J. Burke. 2015. Evaluation of Adult Pacific Lamprey Passage at Lower Columbia River Dam and Behavior in relation to Fishway Modifications at Bonneville and John Dam dams -2014. DRAFT Technical Report 2015-10 by University of Idaho (Department of Fish and Wildlife Sciences) and National Marine Fisheries Service (Northwest Fisheries Science Center) for the U.S. Army Corps of Engineers, Portland District. 55 pp.
- Clabough, T.S., M.L. Keefer, C.C. Caudill, E.L. Johnson, and C.A. Peery. 2009. Use of Night Video to Quantify Adult Pacific Lamprey Passage at Bonneville and The Dalles dams in 2007-2008. Technical Report 2009-9 of Idaho Cooperative Fish and Wildlife Research Unit to the U.S. Army Corps of Engineers, Portland District. 54 pp.
- Clabough, T.S., M.L. Keefer, C.C. Caudill, E.L. Johnson, and C.A. Peery. 2012. Use of Night Video to Enumerate Adult Pacific Lamprey Passage at Hydroelectric Dams: Challenges and Opportunities to Improve Escapement Estimates. *North American Journal of Fisheries Management* 32:687-695.
- Clemens, B.J., T.R. Binder, M.F. Docker, M.L. Moser, and S.A. Sower. 2010. Similarities, differences, and unknowns in biology and management of three parasitic lampreys of North America. *Fisheries* 35:580–594.
- Clemens, B. J., L. Wyss, R. McCoun, L. Schwabe, I. Courter, S. Duery, J. Vaughn, & C. B. Schreck. 2012. Migration characteristics and habitat use of the imperiled adult Pacific lamprey in the Willamette Basin: Prelude to estimating requirements to persistence. Final Draft Report to the Columbia River Inter-Tribal Fish Commission, Portland, OR.

Close, D. A., M. S. Fitzpatrick, and H. W. Li. 2002b. The ecological and cultural importance of a species at risk of extinction, Pacific lamprey. *Fisheries* 27(7):19–25.

Corbett, S.C., M.L. Moser, B. Wassard, M.L. Keefer, and C.C. Caudill. 2013. Development of passage structures for adult Pacific lamprey at Bonneville Dam, 2011-2012. Report to U.S. Army Corps of Engineers, Portland District, Portland, Oregon.

Corbett, S.C., M.L. Moser, K.E. Frick, B. Wassard, M.L. Keefer, and C.C. Caudill. 2014. Development of passage structures for adult Pacific lamprey at Bonneville and John Day Dams, 2013. Report to U.S. Army Corps of Engineers, Portland District, Portland, Oregon.

Corbett, S.C., K.E. Frick, M.L. Moser, B. Wassard, M.L. Keefer, and C.C. Caudill. 2015. Adult Pacific Lamprey Passage Structures: Use and Development at Bonneville Dam and John Day Dam South Fishway, Report to U.S. Army Corps of Engineers, Portland District, Portland, Oregon. 71 pp + appendices.

Daigle, W.R., C.A. Peery, S.R. Lee, and M.L. Moser. 2005. Evaluation of adult Pacific lamprey passage and behavior in an experimental fishway at Bonneville Dam. Idaho Cooperative Fish and Wildlife Research Unit, Technical Report 2005–1. Prepared for the U.S. Army Corps of Engineers, Portland District and Bonneville Power Administration, Portland, Oregon. 41 pp.

Johnson E.L., C.C. Caudill, M.L. Keefer, T.S. Clabough, C.A. Peery, M.A. Jepson, and M.L. Moser. 2012. Movement of radio-tagged adult Pacific lampreys during a large-scale fishway velocity experiment. *Transactions of the American Fisheries Society* 141:571-579.

Keefer M. L., Caudill C.C. and Moser M.L. 2014. Fishway bottleneck relief models: a case study using radio-tagged Pacific Lampreys. *Transactions of the American Fisheries Society* 143: 1049-1060.

Keefer M.L., C.C. Caudill, T.S. Clabough, M.A. Jepson, E.L. Johnson, C.A. Peery, M.D. Higgs, and M.L. Moser. 2013a. Fishway passage bottleneck identification and prioritization: a case study of Pacific lamprey at Bonneville Dam. *Canadian Journal of Fisheries and Aquatic Sciences* 70:1551-1565.

Keefer M.L., C.T. Boggs, C.A. Peery, and C.C. Caudill. 2013b. Factors affecting dam passage and upstream distribution of adult Pacific lamprey in the interior Columbia River Basin. *Ecology of Freshwater Fish* 22: 1-10.

Keefer, M.L., T.C. Clabough, M.A. Jepson, E.L. Johnson, C.T. Boggs, and C.C. Caudill. 2012. Adult Pacific lamprey passage: data synthesis and fishway improvement prioritization tools. Final Technical Report 2012-8. Prepared for U.S. Army Corps of Engineers, Walla Walla District. 116 pp.

Keefer, M.L., C.A. Peery, S.R. Lee, and W.R. Daigle. 2011. Behavior of adult Pacific lamprey in near-field flow and fishway design experiments. *Fisheries Management and Ecology*. 18:177-189.

- Keefer M.L., W.R. Daigle, C.A. Peery, H.T. Pennington, S.R. Lee, and M.L. Moser. 2010. Testing adult Pacific lamprey performance at structural challenges in fishways. *North American Journal of Fisheries Management* 30:376–385.
- Keefer M.L., M.L. Moser, C.T. Boggs, W.R. Daigle, and C.A. Peery. 2009. Effects of body size and river environment on the upstream migration of adult Pacific lampreys. *North American Journal of Fisheries Management* 29:1214–1224.
- Kemp, P.S., T. Tsuzaki, and M.L. Moser. 2009. Linking behavior and performance: intermittent locomotion in a climbing fish. *Journal of Zoology* 277:171–178.
- Kirk, M.A., C.C. Caudill, D. Tonina, and J. C. Syms. 2016. Effects of water velocity, turbulence and obstacle length on the swimming capabilities of adult Pacific lamprey. *Fisheries Management and Ecology*, 23: 356–366.
- Kirk M.A., C.C. Caudill, E.L. Johnson, M.L. Keefer, and T.S. Clabough 2015. Characterization of adult Pacific lamprey swimming behavior in relation to environmental conditions within large dam fishways. *Transactions of the American Fisheries Society* 144:998-1012.
- Lampman, R. T. 2011. Passage, migration behavior, and autoecology of adult Pacific lamprey at Winchester Dam and within the North Umpqua River Basin, Oregon, USA. Master's Thesis, Oregon State University, Corvallis, OR.
- Luzier, C.W, H.A. Schaller, J.K. Brodstrom, C. Cook-Tabor, D.H. Goodman, R.D. Nelle, K. Ostrand, and B. Streif. 2011. Pacific lamprey (*Entosphenus tridentatus*) assessment and template for conservation measures. U.S. Fish and Wildlife Service, Columbia River Fisheries Program Office, Vancouver, WA. 282 pp.
- Madson, P.L and B. van der Leeuw. 2016. Status Report- Pinniped predation and deterrent activities at Bonneville Dam. Fisheries Field Unit, U.S. Army Corps of Engineers Bonneville Lock and Dam Cascade Locks, Oregon. 6 pp. Available online at: <http://www.nwd-wc.usace.army.mil/tmt/documents/fish>
- Mesa, M.G., R.J. Magie, and E.S. Copeland. 2009. Passage and behavior of radio-tagged adult Pacific lamprey (*Entosphenus tridentata*) at the Willamette Falls Project, Oregon, 2005-2007. Prepared by U.S. Geological Survey, Cook, Washington, for Portland General Electric, Portland, Oregon. 40 pp.
- Mesa, M.G., J.M. Bayer, and J.G. Seelye. 2003. Swimming performance and physiological responses to exhaustive exercise in radio-tagged and untagged Pacific lampreys. *Transactions of the American Fisheries Society* 132:483–492.
- Moser, M.L., W.P. Cavender, D.A. Ogden, and C.A. Peery. 2002. Effects of light on migrating adult Pacific lamprey. Pages 37-40 in: M. Moser, J. Bayer and D. MacKinlay, editors. *The Biology of Lamprey Symposium Proceedings*, International Congress on the Biology of Fish University of British Columbia, Vancouver, Canada.

- Moser, M.L., M.L. Keefer, C.C. Caudill, and B.J. Burke. 2013. Migratory behavior of adult Pacific lamprey and evidence for effects of individual temperament on migration rate. Pages 130-149 *in*: H. Ueda and K. Tsukamoto, editors. *Physiology and Ecology of Fish Migration*. CRC Press, Boca Raton, Florida.
- Moser, M.L., M.L. Keefer, H.T. Pennington, D.A. Ogden, and J.E. Simonson. 2011. Development of Pacific lamprey fishways at a hydropower dam. *Fisheries Management and Ecology* 18:190-200.
- Moser, M.L., and M.G. Mesa. 2009. Passage considerations for lamprey. Pages 115-124 *in*: L.R. Brown, S.D. Chase, M.G. Mesa, R.J. Beamish and P.B. Moyle, editors. *American Fisheries Society Symposium 72: Biology, Management and Conservation of Lampreys in North America*. Bethesda, Maryland.
- Moser, M.L., H.T. Pennington, and J.M. Roos. 2008. Grating size needed to protect adult Pacific lampreys in the Columbia River Basin. *North American Journal of Fisheries Management* 28: 557-562.
- Moser, M.L., D.A. Ogden, D.L. Cummings, and C.A. Peery. 2006. Development and evaluation of a lamprey passage structure in the Bradford Island Auxiliary Water supply channel, Bonneville Dam, 2004. Prepared for the U.S. Army Corps of Engineers, Portland District. November 2006. 26 pp.
- Moser, M.L., and D.A. Close. 2003. Assessing Pacific lamprey status in the Columbia River Basin. *Northwest Science*. 77:116-125.
- Moser, M.L., A.L. Matter, L.C. Stuehrenberg, and T.C. Bjornn. 2002a. Use of an extensive radio receiver network to document Pacific lamprey (*Lampetra tridentata*) entrance efficiency at fishways in the Lower Columbia River, USA. *Hydrobiologia* 483:45-53.
- Moser, M.L., P.A. Ocker, L.C. Stuehrenberg, and T.C. Bjornn. 2002b. Passage efficiency of adult Pacific lampreys at hydropower dams on the lower Columbia River, U.S.A. *Transactions of the American Fisheries Society* 131:956-965.
- Moser, M.L., L.C. Stuehrenberg, W. Cavender, S.G. McCarthy, and T.C. Bjornn. 2002. Radiotelemetry investigations of adult Pacific lamprey migration behavior: evaluation of modifications to improve passage at Bonneville Dam, 2000. Report prepared by the Fish Ecology Division, NW Fisheries Science Center, NMFS, Seattle, WA. Report to NMFS and USACE. 84 pp.
- Naughton, G.P., C.C. Caudill, C.A. Peery, T.S. Clabough, M.A. Jepson, T.C. Bjornn, and L.C. Stuehrenberg. 2007. Experimental evaluation of fishway modifications on passage behaviour of adult Chinook salmon and steelhead at lower Granite Dam, Snake River, USA. *River Research and Applications* 23:99-111.
- Porter L.L., M.C. Hayes, A.D. Jackson, B.J. Burke, M.L. Moser, and R.S. Wagner. 2017. Behavioral Responses of Pacific Lamprey to Alarm Cues. *Journal of Fish and Wildlife Management* 8(1).

Reinhardt, U.G, T. Binder, and D.G. McDonald. 2009. Ability of adult sea lamprey to climb inclined surfaces. *American Fisheries Society Symposium* 72:125-138.

Reinhardt, U.G., L. Eidietis, S.E. Friedl, and M.L. Moser. 2008. Pacific lamprey climbing behavior. *Canadian Journal of Zoology* 86:1264–1272.

Robinson, T. C., and J. M. Bayer. 2005. Upstream migration of Pacific lampreys in the John Day River, Oregon: behavior, timing, and habitat use. *Northwest Science* 79:106-119.

Scott, W.B and E.J. Crossman. 1973. *Freshwater fishes of Canada*. Canadian Government Publishing Centre, Ottawa, Canada. pp 42- 45.

Tackley, S.C., R.J. Stansell, and K.M. Gibbons. 2008. Pinniped predation on adult salmonids and other fish in the Bonneville Dam tailrace, 2005-2007. U.S. Army Corps of Engineers CENWP-OP-SRF Fisheries Field Unit Bonneville Lock and Dam Cascade Locks, Oregon. Available online at :http://www.nwd-wc.usace.army.mil/tmt/documents/fish/05-07_Pinniped_Report_Final.pdf

USFWS and USFS (U.S. Fish and Wildlife Service and U. S. Forest Service). 2010. Best management practices to minimize adverse effects to Pacific lamprey (*Entosphenus tridentatus*). April 2010. 25 pp.

Yun, S., A.J. Wildbill, M.J. Siefkes, M.L. Moser, A.H. Dittman, S.C. Corbett, W. Li, and D.A. Close. 2011. Identification of putative migratory pheromones from Pacific lamprey. *Canadian Journal of Fisheries and Aquatic Sciences* 68:2194-2203.

Zobott, H., C.C. Caudill, M.L. Keefer, R. Budwig, K. Frick, M. Moser, and S. Corbett. 2015. Design Guidelines for Pacific Lamprey Passage Structures. Technical Report 2015-5-DRAFT. Prepared for the U.S. Army Corps of Engineers, Portland District, Portland, Oregon. 47 pp.

APPENDIX A.

Case Studies of Fishway Modifications to Improve Pacific Lamprey Passage.

Table A1. List of Case Studies. More will be added as they become available.	
Fishway/ River/ State	Brief Description
Bonneville Dam Fishway <i>Lower Columbia River</i> Washington	Refuge Boxes- Provision of dark refuge areas where lamprey can rest, shelter from daylight, and escape predation.
Priest Rapids Dam <i>Columbia River</i> Washington	Counting window modifications and plating over diffuser gratings and at orifices.
River Mill Fishway <i>Clackamas River</i> Oregon	Newly constructed ladder, designed with lamprey considerations, and high (>90%) passage efficiency.
Three Mile Dam <i>Umatilla River</i> Oregon	Lamprey ramp installation at a diversion dam outside of a fishway.
Walterville entrance to the Adult Fish Return Channel <i>McKenzie River</i> Oregon	New construction of a small fishway entrance with considerations for lamprey.
Willamette Falls fishway <i>Willamette River</i> Oregon	Addition of water source, ramps and channel to reactivate an old channel solely for lamprey to pass; Use of ramps associated with flashboard installation/ dead-ends; Modification of Fishway Entrance- bulkhead inserts.
Vertical Wetted Wall Lamprey Passage Structure Prosser Dam <i>Yakima River</i> Washington	Design and addition of two wetted wall lamprey passage structures at a diversion dam.

Refuge Boxes for Pacific Lamprey in Fishway Bonneville Dam, Columbia River

Background

Many fish species are sensitive to unnatural features in fishways and they may delay or abandon migration when confronted with man-made passage structures. In particular, adult lamprey are nocturnal and have been observed to fall back downstream through fishways when exposed to predators and/or daylight. To reduce this fall back, we placed novel “refuges” (Figure 1) within a fishway at a Columbia River hydroelectric dam to improve retention and passage of adult Pacific Lamprey. Lamprey use of the refuges and the effect of refuge use on passage success were assessed using PIT detections and radiotelemetry.

Design Elements for Pacific Lamprey

In 2012, two refuges were installed in the upper Washington-shore fishway at Bonneville Dam, one along each wall of the auxiliary water supply channel. The channel width at this location is 9.1 m, so the 7 cm refuge openings (orifices) represented 1.5% of the channel cross-section. These low-velocity, dimly lit refuges were fitted with passive integrated transponder (PIT) antennas to detect PIT-tagged adult Pacific Lamprey that were released downstream from the dam. For each 1.1 × 0.4 × 0.2 m refuge (Figure 2), cobble substrate was cemented to the floor at the upstream end. The long axis of each refuge was oriented parallel with the flow and the orifices were positioned at the upstream and downstream ends (Figure 1).

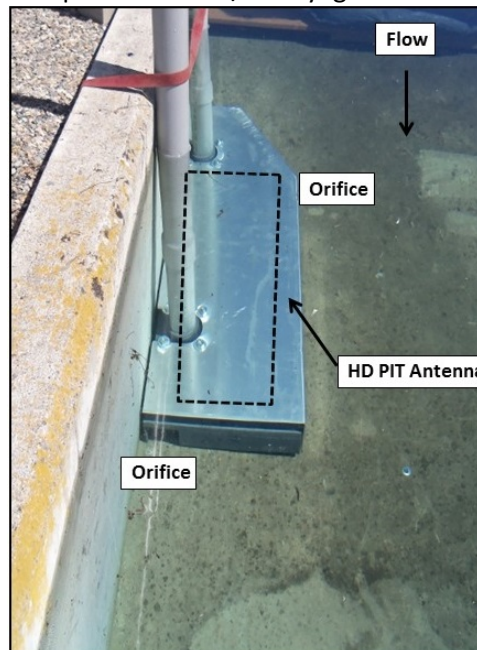

Design Effectiveness

The refuges were operated and evaluated in 2012-14. Each year lamprey captured in the fishway were marked with a 32-mm half-duplex PIT and released approximately 3 km downstream from the dam: 977 in 2012, 1073 in 2013, and 1198 in 2014. In 2014, 599 of the PIT-tagged lamprey were also implanted with a uniquely-coded radio transmitter. Radiotelemetry data from 2014 were used to assess the relative passage success (at and upstream from Bonneville Dam) of lamprey that used a refuge relative to those that did not.

In each year of study, 12 – 35% of the PIT-tagged lamprey that were detected at the fishway exit had used a refuge. Similarly, 29% of the radio-tagged lamprey detected at the fishway exit had used a refuge. The median time that lamprey resided in the refuges each year was 14.2 - 57.2 h, but the variation among individuals was high, with some lamprey staying in a refuge for weeks at a time. The greatest use of the refuges was during the day: entrance rate peaked at 0300 – 0500 hr and lamprey typically left the refuges at around 2000 hr. Lamprey were clearly attracted to and resided in the refuges, as a much higher percentage of lamprey entered the refuges relative to their footprint on the fishway floor. Moreover, refuge usage was likely underestimated due to the high probability of PIT collisions and known antenna outages. Tagged lamprey were regularly detected in the refuges during the day and for periods in excess of 8 h, suggesting that the refuges functioned to retain lamprey that might otherwise have moved back downstream if they were unable to completely pass the fishway during the night.

The mean percentage of PIT-tagged lamprey detected at sites upstream from Bonneville Dam of those detected exiting the fishway was lower for refuge users (68%) than fish that did not use a refuge (79%). For radio-tagged lamprey, refuge users passed upstream from Bonneville Dam at a slightly lower rate (68.3%, 43/63) than non-users (72.1%, 111/154). Radio-tagged lamprey that used a refuge took longer to pass through the study area (mean= 2d, median=0.9 d) than fish that did not use a refuge (mean=0.6 d, median=0.1 d). A higher percentage of radio-tagged refuge users were last detected in the Bonneville Reservoir after passing over the dam when compared to fish that did not use a refuge. Fewer refuge users than non-users had a last detection upstream from The Dalles Dam, the next dam upstream. It is possible that extended residence times in the refuges resulted in lamprey overwintering in lower portions of the Columbia River drainage. While refuges show promise for improving lamprey retention in fishways, further study is needed to insure that these structures do not negatively affect overall lamprey fitness by delaying migration.

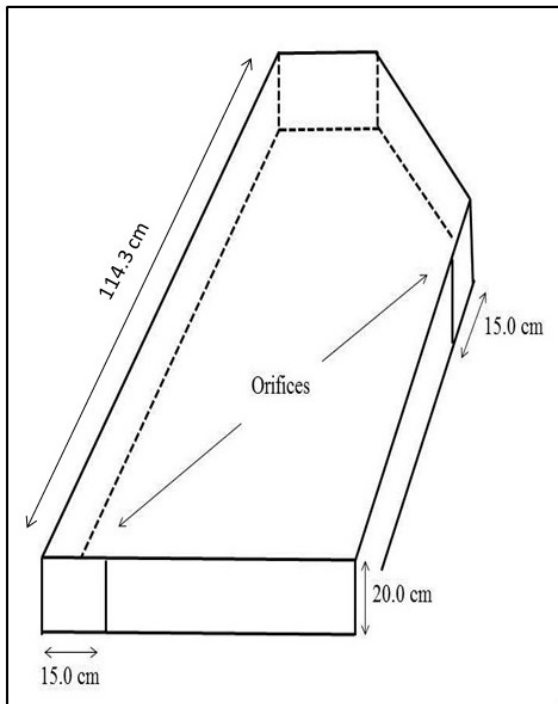

Figure 2. Dimensions of refuge box placed in the auxiliary water supply channel at the Washington-shore fishway at Bonneville Dam.

Project Contact:

Mary Moser

Northwest Fisheries Science Center, National Marine Fisheries Service

2725 Montlake Blvd. East

Seattle, WA 98112

mary.moser@noaa.gov

Priest Rapids & Wanapum Fishway and Counting Station Modifications -- Grant P.U.D.

Background

Priest Rapids and Wanapum dams, collectively referred to as the Priest Rapids Project were constructed on the mid-Columbia River in the early 1960's. As part of their FERC license requirements, Grant County PUD installed several new structures in the existing fishways at both dams to improve lamprey passage. Improvements were made to the counting station that forced upstream migrating lamprey to pass at this location and improve count accuracy. In addition, flat aluminum plating to provide attachment surfaces around all existing floor diffusers was installed. Grant P.U.D. completed these upgrades in 2010, which were subsequently evaluated using underwater video.

Design Elements for Pacific Lamprey

The Priest Rapids and Wanapum fishways are similar in design with both orifice and overflow weir features. Priest Rapids flows range from 12-16 cfs and ascends ~ 74 vertical feet while Wanapum ranges in flow from 12-14 cfs and ascends ~72 vertical feet. The newly installed structures included flat aluminum plating on perimeter of all diffusion grating pools (approximately 16 inches in diameter, Fig.1) and through all weir orifice openings (Fig. 2). The count station was also redesigned to force lamprey to pass through the counting window (Fig. 3), thereby improving accuracy of the adult lamprey counts (previous count stations utilized picketed leads which were easily accessed by adult lamprey). The new count stations includes: a crowder and lamprey ramp angled to guide lamprey to the window (open gap size of 11/16"); a solid ramp leading to the window entrance (approximately 16 inches diameter at ~ 45 degree pitch), and plating (1/4" thickness) at the floor-to-crowder transition to improve guidance.

Design Effectiveness

To evaluate the effectiveness of the lamprey passage modifications, multiple underwater video cameras were installed at strategic locations to collect video imagery of "lamprey events" at these structures. Each event was analyzed according to a behavior protocol; the utility of structures was inferred from summary statistics of behavior criteria.

A total of 23 events were documented at the orifice with aluminum plate. Seven out of 10 lamprey approached the orifice from the immediately downstream and over the diffuser grating. All lamprey swam in the lower half of the orifice, with 95% (18/19) passing on the first attempt, and 100% passing on the second attempt. Most (78%) traveled along the center of the plate and all (95%) attached to the plate at least once. Rare attachments off the plate suggests the plating dimensions are adequate. Plating at the orifice was extensively used, events were of short duration, and all passage attempts were successful.

A total of 123 events were documented at the crowder/counting station; 93 of those events were passage attempts. Of the 93 lamprey that attempted to pass, 94% (87 fish) succeeded. Forty-three percent of those fish use the solid ramp. Plating at the crowder was used by about half of the migrants and search behaviors for count entrance were largely successful. Overall, the crowder guided most lamprey to the chute. Lamprey behavior indicates that plating facilitates passage.

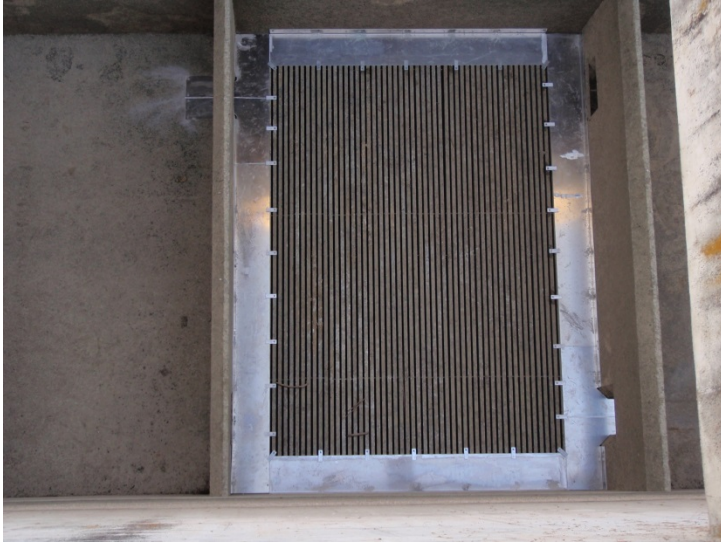

Figures 1-2. Photos of Priest Rapids fish ladder, showing use of flat plating for attachment.



Figure 3. Priest Rapids fishway- approach to counting window and modifications for lamprey.

Project Contact:

Mike Clement
Natural Resources, Grant P.U.D.
Ephrata, WA
Mclemen@gcpud.org

River Mill Dam Fish Ladder – Clackamas Hydro Project Portland General Electric

River Mill Dam was completed on the Clackamas River, Oregon in 1911. At the time, the fish ladder included as part of the dam project was considered state-of-the-art. By modern day standards however, the River Mill ladder lacked many of the design elements considered standard even for salmon passage. While passage for steelhead trout and coho salmon was reasonable, the overflow weir style ladder with its short cells, tight turns, and relatively low flow volume posed a challenge to Chinook salmon. No design elements for Pacific Lamprey were included, and the ladder exit with its false weir type design was likely a barrier to lamprey passage. As part of re-licensing the Clackamas Hydro Project, PGE replaced the original ladder, completing the new ladder in late 2006.



Design Elements for Pacific Lamprey

The River Mill ladder was designed to meet all applicable design standards for passage of anadromous salmonids. The ladder is a half Ice Harbor style ladder operated with a flow of approximately 19 cfs and ascends a height of approximately 85 feet. The ladder includes several design characteristics to facilitate the passage of Pacific Lamprey adults. These design elements include:

- Rounded entrance corners (6" radius)
- Flush mounted entrance gates sit within bulkhead slots for smooth attachment (Figure 1)
- ¾" spacing floor diffuser gratings
- 12" solid concrete floor on either side of floor diffuser gratings for lamprey attachment
- A secondary ladder entrance with a head differential of 0.75 ft (lower velocity relative to primary entrance)
- 6" chamfered upstream and downstream edges of weirs and orifices (Fig. 1)
- Continuous attachment along walls adjacent to weirs
- Rounded corners throughout ladder (Fig. 1)
- Adjustable exit weirs have filled bulkhead slots



Figure 1. Photos of Pacific Lamprey passage design elements of the River Mill fish ladder. Rounded entrance and filled entrance gate bulkhead slot (left), chamfered orifice and weir (middle) and rounded ladder corner (right).

Design Effectiveness

Adult Pacific Lamprey passage evaluations of the River Mill fish ladder were conducted in 2013 and again in 2015. In both years, dual tagged (PIT and radio) and PIT tagged fish were released approximately 1km downstream of the dam. Fish receiving tags had previously been captured in a trap in the River Mill ladder. In 2013, dam passage rate estimates were 84% and 96% for dual tagged and PIT tagged fish respectively. When the study was repeated in 2015, the results from 2013 were confirmed with passage rate estimates of 90% and 94% for dual and PIT tagged lamprey. For dual tagged fish, passage rate estimates were derived by dividing the number of fish that successfully passed the dam by those that approached the tailrace. Passage rate estimates of PIT tag fish were estimated by dividing the number that passed the dam by the number released.

Taking a more refined look with radio tag data, the entrance efficiency of the ladder (number entering out of number approaching) was 90-92%, with 94-100% of fish that entered the ladder successfully reaching the forebay. Passage times confirm the efficacy of passage at River Mill. The median time spent from arrival in the tailrace until arrival in the forebay was 1.6 d in 2013 and 2.1 d in 2015 while median passage time through the ladder itself was only 0.9 d and 0.7 d respectively.

Among the two ladder entrances, radio tagged lamprey predominately used the primary ladder entrance despite the higher entrance velocity. For example, in 2015 of 20 successful ladder entries made by radio tagged lamprey 19 of them occurred at the primary entrance. This was driven by the fact that there were far more approaches to the primary entrance. The primary entrance is on the powerhouse side of the dam where the preponderance of attraction flow to the dam exists.

Table 1. River Mill Dam passage rate estimates of PIT and dual tagged Pacific Lamprey in 2013 and 2015.

Year	Tag Type	# Released/In TR ¹	Estimate Passing ²	Passage Rate	
				Estimate	95% CI
2013	PIT	42	40.3	96%	68-100%
	Dual	37	31.0	84%	69-92%
2015	PIT	51	47.6	94%	86-100%
	Dual	20	18.0	90%	77-100%

1. Number released for PIT tagged fish and number arriving in the tailrace for dual tagged fish.
2. Consider estimate of number passing for PIT tagged fish after accounting for detection efficiency of the PIT antenna array.

Project Contact:

Nick Ackerman
Senior Scientist
Portland General Electric
33831 S. Faraday Rd.
Estacada, OR 97023
503-630-8232
nick.ackerman@pgn.com

Three Miles Falls Dam Umatilla River, Oregon

Background

Three Miles Falls Dam is the first major obstacle that pre-spawning adult Pacific Lamprey encounter in the Umatilla River, Oregon. It is fitted with a fish ladder that has been shown to have low passage efficiency for lamprey (Jackson and Moser 2012). The Confederated Tribes of the Umatilla Indian Reservation secured funding from the U.S. Fish and Wildlife Service and Bonneville Power Administration to install a lamprey-specific passage system (LPS) in summer 2009. The LPS design was developed in consultation with a variety of fish and water management agencies and it was positioned next to the existing fishway entrance to minimize effects on other species, while affording the best possible access for lamprey.

Design Elements for Pacific Lamprey

Modular LPS elements were designed and fabricated at the Pasco Research Station (National Marine Fisheries Service) and transported for installation at the dam. The structure was made of aluminum (5052 alloy sheet aluminum and 6061 alloy structural shapes) with all stainless steel fasteners to reduce weight, prevent corrosion, and allow flexibility in design modification and installation. All elements were fabricated using fish-friendly construction (i.e., no rough edges, all corners rounded, no metal burrs, no application of caustic agents, etc.). For installation, each element was custom-fitted on site during low water conditions (Figure 1).



Figure 1. Photos of Three Mile Falls LPS with dual 60° entrance collector ramps that terminate in a large rest box (left). The 45° climbing ramp from the rest box to the exit slide was covered to protect lamprey from predators and reduce algal growth on the ramp (right). This ramp terminated in a horizontal section leading lamprey through an HDX-PIT antenna, into an upwelling box, and down an exit slide to an open trap box in the dam forebay.

Ambient Umatilla River water was pumped to the upwelling box at the structure's terminus to maintain approximately 2 cm depth on the LPS ramps. Lamprey passed through the upwelling box and dropped into a trap box where they could volitionally exit to the dam forebay. A mechanical counter was positioned at the terminus of the exit slide to enumerate lamprey passing into the trap box.

Design Effectiveness

Adult Pacific Lamprey passage evaluations at Three Mile Falls were conducted from 2005 – 2014 using radiotelemetry (Jackson and Moser 2012). In addition, LPS use by HDX-PIT-tagged adult lamprey was assessed from 2009 to 2014 and counts made at the LPS exit were compared to those made at the fishway, along the eastern wall of the dam and via assessment traps (Figure 2). Prior to LPS installation, mean fitted probability of lamprey passage at Three Mile Falls Dam was 25% (Jackson and Moser 2012). After LPS installation, average passage efficiency for radio-tagged lamprey was 44%. In addition, the proportion of lamprey using the LPS relative to other passage routes increased steadily after LPS installation (Figure 2). Planned improvements include the installation of covers on the collector ramps to protect lamprey from otter and bird predation (which has been documented in recent years).

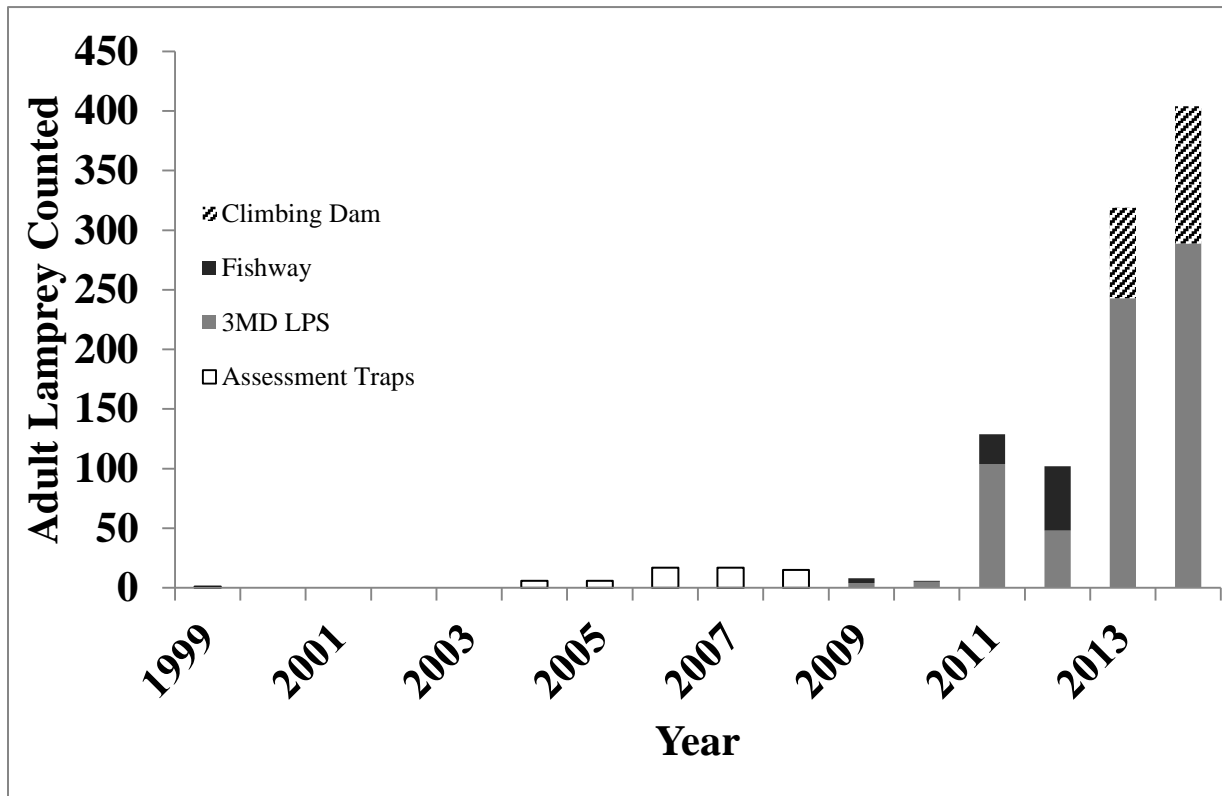

Figure 2. Lamprey counts at the LPS at Three Mile Falls Dam (gray bars) relative to counts at the fishway (solid bars), climbing vertically along the wall on the dam's east side (counting started in 2013, hatched bars), or captures in assessment traps at the fishway entrance (operated 1999-2009, open bars).

Jackson, A.D. and M.L. Moser. 2012. Low-elevation dams are impediments to adult Pacific Lamprey spawning migration in the Umatilla River, Oregon. *North American Journal of Fisheries Management* 32:548–556.

Project Contact:

Aaron Jackson,
 Tribal Fisheries Program, Department of Natural Resources
 Confederated Tribes of the Umatilla Indian Reservation
 46411 Timine Way, Pendleton, Oregon, 97801
 aaronjackson@ctuir.org

Adult Fish Return Channel Fish Ladder Walterville Hydro Project, McKenzie River, Oregon Eugene Water & Electric Board

Background

The adult fish return channel (channel) for anadromous fish at the Walterville tailrace barrier is intended to provide a route of passage away from the tailrace and back to the mainstem McKenzie (Figure 1). Prior to construction of the channel, fish were attracted to the outflow from the Walterville tailrace, and observations of salmon holding below the tailrace barrier were of concern. To increase attraction into the channel, modifications were made in 2010 to the entrance of the channel adjacent to the tailrace barrier. These modifications included new construction of a two-step, vertical slot fishway to improve the volume and velocity of water for attraction.

Design Elements for Pacific Lamprey

The new fishway at the channel was designed to meet all applicable design standards for passage of anadromous salmonids. The ladder is operated with a flow of approximately 26 cfs and ascends a height of approximately 2 feet. The ladder includes several design characteristics to facilitate the passage of Pacific Lamprey adults. These design elements include:

- Rounded entrance corners (6" radius)
- Entrance gate designs so there are no bulkhead slots in the lowest 12" (Figure 2-left).
- Rounded step at entrance (6" radius)
- Continuous attachment along walls adjacent to weirs as rounded edges used throughout ladder.



Figure 1. Overhead view of the Walterville Tailrace and Adult Fish Return Channel on the McKenzie River.



Figure 2. Photos of Pacific Lamprey passage design elements. Rounded entrance walls and step, and lack of bulkhead slot in the lower 12", immediately above the step (left, looking upstream); rounded entrance walls and slot from above (right).

Design Effectiveness

No specific passage studies for Pacific Lamprey have been conducted at this facility to date.

Project Contact:

Andy Talabere
Fish Biologist
Eugene Water and Electric Board
Andrew.Talabere@EWEB.org
541-685-7397

Willamette Falls Hydro Project- Willamette River, Oregon Portland General Electric

Background

Willamette Falls is a naturally occurring, horseshoe-shaped, 40 ft high basalt rock formation that marks the upstream boundary of tidal influence on the Willamette River. A concrete cap ranging from 6-20 ft runs the entire 2,950 ft crest of the Falls. During summer low flow conditions, wooden flashboards are installed along the concrete cap to increase river elevation and flow through the PGE Sullivan Powerhouse. In 2007, a flow control structure was constructed at the apex of the Falls to focus flow in a location that provides safe and efficient passage for downstream migrating fish.

In 1880 the first fish ladder was completed at Willamette Falls by blasting stepped pools into the solid rock of the Falls. In 1971, fish passage was again improved when Oregon Department of Fish and Wildlife (ODFW) finished construction of a new fish ladder. Part of the new ladder bisects the original ladder creating a passage barrier at the point of intersection. The new ladder consists of three separate legs that join in a common area referred to as Pool-48. Upstream of Pool-48 is the ODFW fish viewing window where pickets are used to crowd fish in front of the window for enumeration. Upstream of the fish viewing window the ladder exits into the forebay between the Falls and the Sullivan Powerhouse.



Design Elements for Pacific Lamprey

Steps to improve lamprey passage have been taken at a number of areas around the Falls. Improvements were made to the fish ladder leg 1 entrance, construction was completed upstream of the old fishway to provide passage into the forebay, and three lamprey ramps are installed annually with the construction of the flashboards along the cap.

Fish Ladder Leg 1: Original construction of the Willamette Falls fish ladder predated lamprey passage design elements. Modifications were made to the leg one entrance to improve passage for lamprey entering through the “cul de sac” side of Willamette Falls at the Sullivan Powerhouse tailrace. These modifications include:

- Chamfered edges for continuous attachment around entrance corners
- Entrance gate with filled bulkhead slot
- Orifice of entrance modified to reduce water velocity to accommodate Lamprey burst swimming speeds through a wide range of tailrace elevations.
- Continuous attachment points on the floor and walls at the entrance to leg 1.

Old Fishway: The old fishway was abandoned with the construction of the new fish ladder in 1971. This area still receives water from normal river flow into late spring, attracting migrating lamprey to the area. Once in the old fishway there is no available route for upstream passage. Stranded lamprey are observed in this area annually and were previously removed through manual salvage. In 2009 steps were taken to create passage from the terminal end of the old fishway over the cap:

- 12" to 24" fine aggregate concrete curb accommodating changing slope as it traverses 180 linear feet and 8' of elevation. Rounded edges and smooth aggregate provide attachment points along the length of the structure.
- 8" flow valve providing 2-4cfs depending on forebay elevation
- Adjustable exit gate for changes in forebay elevation
- 8" diameter at top of exit gate
- 3/16" Buna rubber gasket material draped over the face of the exit gate to remove seams created where the two panels bifurcate.
- Fine aggregate smooth concrete step below exit gate with a rounded 90 degree corner to provide continuous attachment surface.



Figure 1. Photos of lamprey curb with flow line open (left) and lamprey exit gate, smooth concrete step, and 8" flow line (right).

Flashboard Lamprey Ramps: Wooden flashboards installed on top of the cap create a passage barrier for lamprey that attempt to ascend the falls during low flow conditions. Passage over the flashboards is provided by annual lamprey ramp construction. Lamprey ramp location is consistent from year to year and was chosen based on lamprey congregation observations. Specific design elements include:

- Smooth epoxy coated section of concrete cap directly below ramp (cleaned annually to remove algal mat to improve lamprey's ability to "suction" onto surface)
- 4" curb with 12" wide resting pool running the length of the ramp
- 3/16" Rubber mat facing for flashboards and resting curb
- 6" diameter rounded transition at top
- Rope avian Deterrent structure
- "Cattle guard" to reduce debris accumulation
- 1- 6" varying flow depth across top of lamprey ramp
- Fast installation

Design Effectiveness

In 2009, 145 lamprey were captured in the fish ladder or by hand from Willamette Falls, implanted with a radio tag, and released 1.5 miles downstream. Of the 145 tagged fish, 135 fish returned to the vicinity of the Falls. As the percentage of river flow through the powerhouse increased in the summer, use of ladder leg 1 became more prevalent. Overall, fifty seven (42%) of these fish successfully passed the Falls and all did so through the ODFW fish ladder with 68% passing through leg 1. Eighty three percent of fish entering leg 1 (N=39), 70% of fish entering leg 2 (N=7), and 100% of fish entering leg 3 (N=11) passed upstream successfully. Tagging and monitoring efforts completed by the Confederated Tribes of the Warm Springs (CTWS) have found similar passage rates with 28.4% to 45.9% of lamprey released below the Falls successfully passing through the fish ladder (Baker and McVay 2015).

Immediately following dewatering of the old fishway in the spring the area is accessed to open the 8" flow valve and to place the exit gate into operation. It is not uncommon to observe hundreds of lamprey in the channel below the gate when the area is first accessed. After opening the exit gate lamprey are regularly observed ascending the exit gate and during subsequent trips to the area there are very few, if any, lamprey remaining. In 2014, camera monitoring was completed by the CTWS to enumerate fish ascending over the exit gate. This work showed a total of 1,748 lamprey passing the structure with half of the lamprey ascending in the first 24 hours after gate opening (Baker and McVay 2015).

Similar to passage at the old fishway, the highest usage of lamprey ramps over the flashboards is observed shortly after the ramps are placed into service. There is

very little new recruitment to the ramps under the decreased flow conditions and fish that are in the channels below the ramps vacate the area relatively quickly. Lamprey use at these structures has been observed to vary from year to year indicating that timing of flashboard construction and lamprey distribution affect usage.



Figure 2. Rubber faced lamprey ramp and resting pool curb (left), debris “cattle guard” (center), and epoxy coated concrete and avian deterrent (right).

Reference:

Baker, C., and C. McVay. 2015. Willamette Falls Lamprey Study. 2014. Annual Report to BPA, Project No. 2008-308-00, Confederate Tribes of Warm Springs Reservation of Oregon. Warm Springs, OR.

Project Contact:

Dan Cramer
Fish Biologist, Portland General Electric
Dan.cramer@pgn.com ; 503-630-8127

Yakima River Prosser Dam Vertical Wetted Wall Lamprey Passage Structure

Ralph Lampman, Yakama Nation Fisheries Program

RD Nelle and Ann Grote, USFWS Mid-Columbia Fish and Wildlife Conservation Office

Jim Simonson, Fishhead Technology

Susan Camp, Bureau of Reclamation Pacific Northwest Region

Background

Prosser Diversion Dam, constructed in 1904 by private interests and now operated by the Bureau of Reclamation, is located at the City of Prosser (river km 75). The facility consists of a concrete weir structure (2.7 m tall, 201 m long), an irrigation and power generating canal on the left bank (Chandler Canal with 1,500 ft³/s capacity), and three vertical slot fishways (Figure 1). Over the last two decades, the number of adult Pacific Lamprey returning to the Yakima River has been minimal, with counts at Prosser Dam ranging from 0 to 86 individuals per year. Radio telemetry studies of Pacific lamprey from 2012 – 2014 found that overall passage efficiency for lampreys that approached Prosser Dam was 48% (36% during the fall and 53% during the spring). Video counts indicate that Pacific Lampreys use all three fishways, but use of each ladder changes seasonally (Figure 2). This seasonal variation indicates that several passage routes may be needed to provide successful passage for significant numbers of migrants.

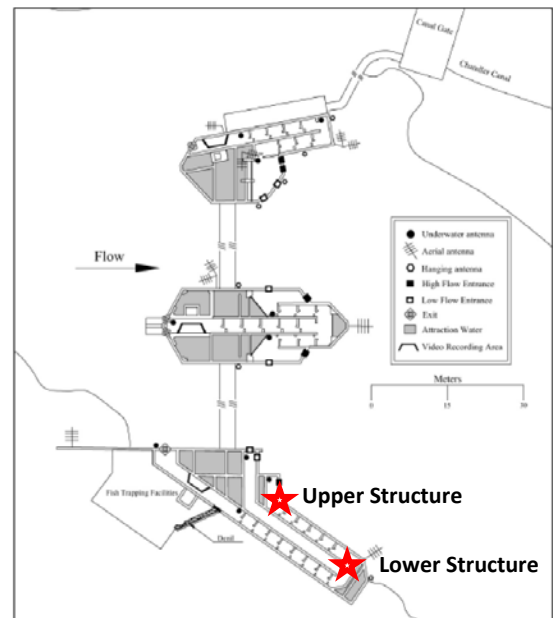

Figure 1 (above). Schematic drawing of the right, center, and left fishways at Prosser Dam. Locations of the two new vertical wetted wall passage structures are also shown (red stars).

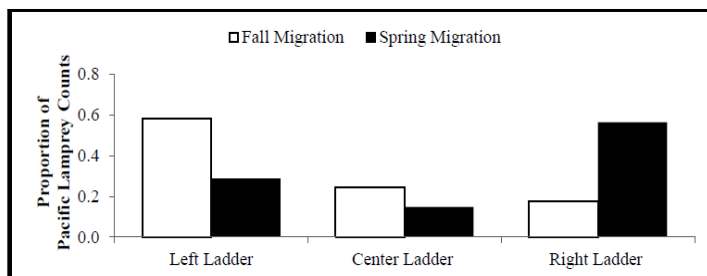

Figure 2 (left). Proportion of adult Pacific Lamprey video counts by migration season (fall and spring) and ladder location (left, center, and right) at Prosser Dam.

Vertical Wetted Wall Lamprey Passage Structure

A unique behavior of Pacific Lamprey is their ability to climb vertical walls where water sheets down the surface. As a result of multi-agency collaboration, two vertical wetted wall (VWW) lamprey passage structures (designed by Fishhead Technology) were deployed at Prosser Dam on November 7, 2016, to provide alternative passage options for adult Pacific Lamprey (Photo 1). Each VWW consists of a vertical aluminum sheet that extends into the water with a smooth radius crest that lead to a holding tank with a submersible sump pump (Dayton Model #1XHV7 ½ HP). Flow rate is approximately 60 gpm, with 10 ft of head. The vertical portion is 8-14 ft high, depending on river flow levels. The VWWs were deployed well before the regular lamprey passage season to allow aluminum to “age” to reduce the presence of repellent olfactory cues from construction. Locations for the VWWs at Prosser Dam (Figure 1) were determined based on radio telemetry results, local best knowledge, and ease of access. Although the VWW is still an experimental device, the primary advantages are: 1) proven way



to effectively pass lamprey, 2) cost effectiveness, 3) ease of construction, operation, maintenance, and modification with a modular design, and 4) compatible with current infrastructure with a very small footprint in the water. Once the best locations for the VWW lamprey passage structures are verified, volitional passage can be attained by linking the VWW to other ramp or pipes to reach the forebay of the dam.

Photo 1. Vertical Wetted Wall Lamprey Passage Structures installed at Prosser Dam (left - Lower Structure, right - Upper Structure). The vertical center guide pipe allows lamprey that are passing along the ladder wall from either directions to sense the flowing water.



Photo 2. Lamprey successfully passing the radius curve on April 30, 2017 (1st night after the round magnets were added) (left photo). Strategically placed magnets effectively break up the flow and allow lamprey to choose the best path for their passage based on their preferred flow conditions (right photo shows the view from the top with multiple lamprey climbing the center with a flow break created by the magnets).

Lesson #1A: The flow rate needs to be balanced effectively to maximize both attraction and ease of access. Too much flow will make the climbing difficult (most lamprey only traveled close to the edges where they encounter reduced flow) and too little flow will limit the attraction and motivation of lamprey to climb. **Resolution ->** use the maximum flow from one pump (~60 gpm in our case) but add small round magnets (2-3" diameter) that break up the laminar flow and produce diverse flow conditions. Variable flows and hydrologic "micro-features" on the VWW effectively created many alternative routes that lamprey used to climb in addition to the edges of the structure (Photo 2). Lamprey were also observed using a "buddy system" in which lamprey upstream acted as a flow buffer for lamprey downstream, aiding their climbing; magnets in essence served this role (without the presence of lamprey).

Lesson #1B: Small distinct ridges on the radius curve made it very difficult for lamprey to maintain their suction. **Resolution ->** grind down the ridge lines on the radius curve to make it as smooth as possible.

Lesson #2: Many lamprey did not enter the holding tank immediately after climbing to the top of the VWW and a portion of them fell back down the VWW. These fallbacks and delays were likely due to 1) the confusing attractant flows through perforated plates near the entrance to the holding tank and 2) the shape of the tank entrance (a 90 degree bend). **Resolution** -> adding a solid aluminum sheet on the bottom panel near the entrance hole reduced the amount of searching behavior (likely for flow); and reducing the angle of the bend substantially decreased the “wandering” and “holding” behavior at the entrance.



Photo 3. Lamprey passing through the curved radius with minimal effort after the ridge lines on the radius curve were smoothed out allowing for improved oral disk suction. See Photo 2 (left) for the “before” photo (equally-spaced horizontal ridge lines that are narrower than the lamprey’s mouth).

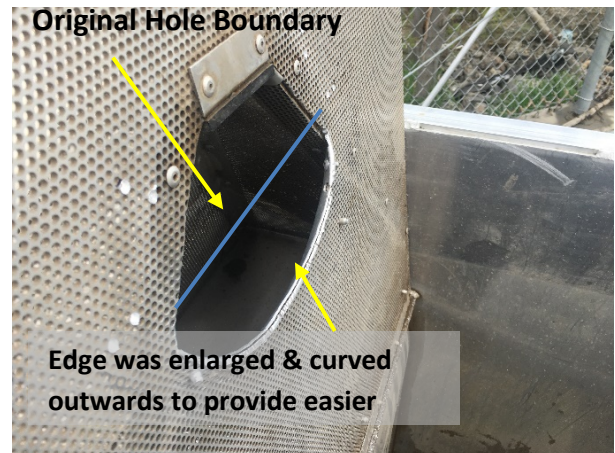

Photo 4. The original hinged fyke design for the entrance was all perforated but a solid plate was added on top of the bottom perforated plate later to reduce the confusion that lamprey seems to encounter from the diffused flow (left photo, blue polygon shows the original hole). Additionally, the hole was enlarged later with a curved round radius to provide easier access for the lamprey (right photo).

Lesson #3: Lamprey can escape the trap box through the entrance hole. **Resolution** -> a few varieties of add-on fyke designs (using frames or funnels) were effective in preventing escapement (with the least amount of resistance to enter the hole). A rubber sheet design was examined but it was not effective in preventing all escapement and also created entrance issues.

Other key design elements to consider:

1. Structure location is critical (all lamprey collected to date are from the Upper Structure and none were captured at the Lower Structure). Interface of fast and slow water at the Upper Structure appears to provide effective attraction; flow near the Lower Structure is predominantly slow water.
2. Most lampreys that climbed the side walls were not successful in reaching the top due to difficulty maintaining suction and transitioning to the frontal wall. Reducing the height of the covered aluminum box

section to prevent lamprey from accessing the side walls during high flow events will likely prevent this issue (alternatively, a ledge can be added to the bottom of the side walls to prevent this completely).

3. Attempts by lamprey to climb the VWW have occurred between 8pm-4am (though some holding/resting behavior was observed outside this time range on a few occasions).
4. Video system activation based on motion detection is entirely non-functional with passive infrared sensors (due to the lack of heat sources in cold-blooded lamprey). Motion detection that operates on image or audio (i.e. splashing noise) sensors may provide better results and will be tested. Mechanical counters (preferably with wireless time stamps) are another option for monitoring their use, but the design needs to be configured carefully to ensure accurate counting (and lack of entrance resistance).
5. It is important to note that the spring migrating lamprey have overwintered and may have reduced bioenergetic reserves compared to summer/fall migrants that have not overwintered. The energetic limitations displayed by spring migrants here may be less severe for the summer/fall migrants; however, 100% passage for all migrants should be a goal for all dams.
6. Effectiveness of adult lamprey in attracting other adult lamprey is currently being tested using live adults in PVC traps within the trap box, but results are still inconclusive.



Photo 5. Examples of fyke designs that were successful in funneling lamprey to the trap box (the hinged fyke plate is lifted to show the hole end of the fyke design). An 8.25" diameter funnel with drinking straw extension (left photo). An 8.25" diameter funnel with zip tie extensions (center photo). A metal frame with vexar plastic covering and zip tie extension (right photo); this design was later modified to reduce the sharp angle that lamprey has to turn to enter (reduced it from 135 to 45 degrees). These designs allow lampreys to pass through while preventing those in the trap from escaping. Vexar plastic covering was also glued to the inside of the funnels to prevent lamprey from resting inside the funnel (which prevented other lamprey from accessing the hole).

Design Effectiveness

Initial passage evaluations of the VWW Lamprey Passage Structures were conducted in Spring 2017. The first lamprey was captured on April 19, 2017, and within a month (by May 11, 2017) over 50 wild lampreys were captured in the Upper Structure. The number of lamprey passing through the existing fish ladder during this same period was 123 (VWW proportion was 29%).

Initial video monitoring indicated that only 10-30% of the lampreys accessing the bottom of the VWW were eventually captured at the holding tank. Three key issues were identified as a result of behavior testing and night-time wireless video monitoring (Netgear Arlo cameras): 1) difficulty in climbing up the VWW all the way, especially at and immediately below the radius section, 2) reluctance to pass the entrance hole at the upper terminal, and 3) ability to escape the holding tank. A number of modifications were made based on the following lessons learned, which lead to substantially improved passage rates within the VWW passage structure over the season.



Photo 6. Lamprey struggling to climb the radius curve at the top of the vertical wetted wall prior to the addition of magnets and smoothing of the ridge lines (horizontal equal-spacing lines).

References:

U.S. Bureau of Reclamation. 2016. Project Alternatives Solution Study (PASS) Final Report for Lamprey Passage, Yakima River Diversion Dams. Pacific Northwest Region, Boise, Idaho.

Project Contact

Ralph Lampman
Lamprey Research Biologist, Yakama Nation Fisheries
PO Box 151, Toppenish, WA 99350
lamr@yakamafish-nsn.gov
509-388-3871